

valvole di blocco a comando pneumatico G1/8"

pneumatically piloted stop valves - G1/8"



11.044.4

valvola di non ritorno a sblocco pneumatico con attacchi G1/8"
non-return valve with pneumatic unlock - ports G1/8"

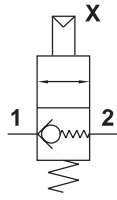

11.066.4

valvola di blocco a comando pneumatico con attacchi G1/8"
pneumatically piloted stop valve - ports G1/8"

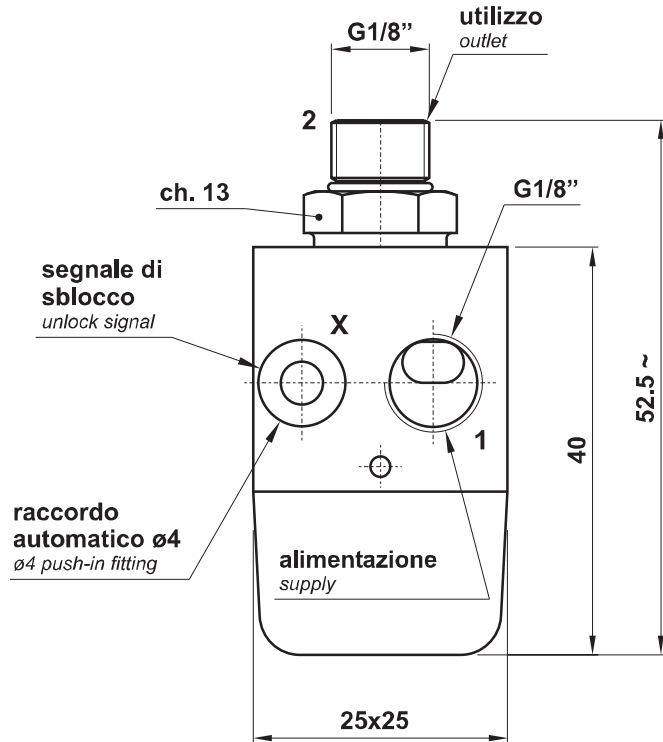
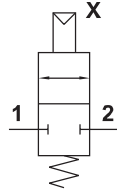

Portata della valvola in funzione della pressione di alimentazione.
Flow rate related to supply pressure.

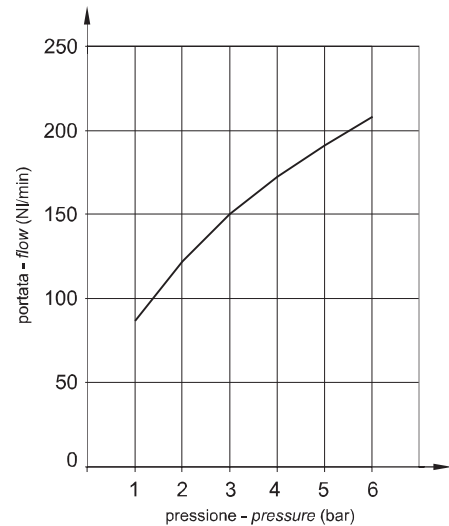

Pressione di sblocco in funzione della pressione di alimentazione.
Unlock pressure related to supply pressure.

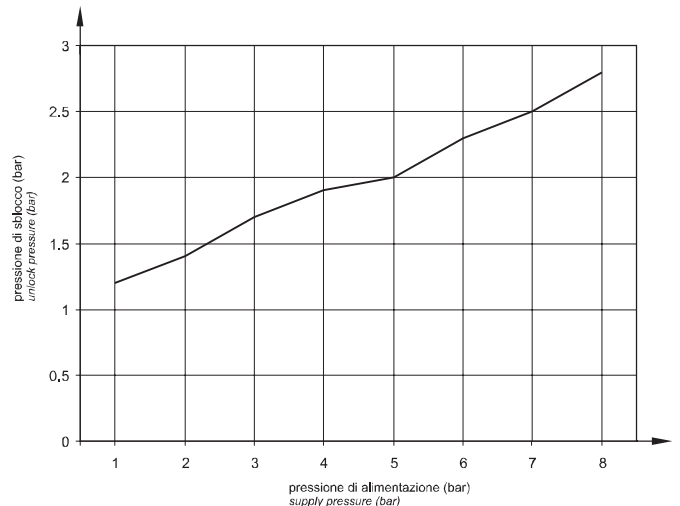

Materiali

Corpo: alluminio 11S
Fondello: DELRIN
Molle: INOX
Guarnizioni: NBR
Parti interne: ottone OT58

Materials

Main body: aluminium 11S
Lower body: DELRIN
Springs: stainless steel
Seals: NBR
Internal parts: brass OT58

Attacchi: alimentazione e utilizzo <i>Ports: supply and outlet</i>	G1/8"
Attacchi: segnale di sblocco <i>Ports: unlock signal</i>	automatico ø4 <i>ø4 push-in</i>
Diametro nominale <i>Nominal orifice</i>	3.5 mm
Temperatura di esercizio <i>Temperature range</i>	max +60°C
Pressione di esercizio <i>Working pressure</i>	max 10 bar max 1 MPa
Fluido <i>Fluid</i>	Aria filtrata 50µ con o senza lubrificazione <i>50µ filtered, lubricated or non lubricated air</i>