





- For threaded connections
M5, G $\frac{1}{8}$... G $\frac{1}{2}$
- For tubing I.D.
3 ... 13 mm
- Aluminium or polymer design
- With sealing ring or moulded-on sealing ring

Quick connectors CK/CX

Product range overview







FESTO

Design	Design	Type	Connection D1		Tubing I.D.	Free of copper, PTFE and silicone	→ Page/ Internet
			M thread	G thread			
Straight	Quick connector – Female thread with sealing ring						
		ACK Metal type	–	G 1/8	3, 4, 6	■	5
				G 1/4	4, 6		
				G 3/8	6, 9		
				G 1/2	13		
	Quick connector – Male thread with sealing ring						
		CK Metal type	M5	–	3, 4	■	6
			–	G 1/8	3, 4, 6		
				G 1/4	4, 6, 9		
				G 3/8	6, 9, 13		
				G 1/2	13		
		CK-...-KU Polymer design	–	G 1/8	3, 4, 6	■	6
				G 1/4	4, 6, 9		
				G 3/8	6, 9		
	Bulkhead quick connector – Female thread with sealing ring						
		QCK	M5	–	3	■	7
			–	G 1/8	4		
				G 1/4	6		
G 3/8				9			
Bulkhead quick connector							
	SCK Metal type	–	–	3, 4, 6, 9	■	8	
	SCK-...-KU Polymer design	–	–	3, 4, 6, 9	■	8	
End cap for plastic tube connectors and barbed connectors							
	CV-PK	–	–	3, 4, 6, 9	–	9	

Quick connectors CK/CX

Product range overview







FESTO

Design	Design	Type	Connection D1			Tubing I.D.	Free of copper, PTFE and silicone	→ Page/ Internet		
			M thread	R thread	G thread					
L-shape	Elbow quick connector									
		GCK-...-KU	-	R 1/8	-	-	4, 6	■	10	
				R 1/4			4, 6			
				R 3/8			6, 9			
	Elbow quick connector, rotatable, with 2 sealing rings									
		LCK Metal type	M5	-	-	-	3, 4	■	11	
							G 1/8			3, 4, 6
							G 1/4			4, 6, 9
							G 3/8			6, 9, 13
							G 1/2			13
	LCK-...-KU Polymer design	-	-	-	-	-	4, 6	■	11	
							G 1/4			4, 6
Elbow quick connector with sealing ring (rotatable 360°)										
	LCKN	M5	-	-	-	3, 4	-	12		
						G 1/8			3, 4, 6	
						G 1/4			4, 6	
						G 3/8			6	
T-shape	T quick connector, rotatable, with 2 sealing rings									
		TCK Metal type	M5	-	-	-	3, 4	■	13	
							G 1/8			3, 4, 6
							G 1/4			4, 6
							G 3/8			6, 9
							G 1/2			13
	TCK-...-KU Polymer design	-	-	-	-	-	4, 6	■	13	
							G 1/4			4, 6
	T-distributor									
		FCK-...-KU	-	-	-	-	3	■	14	
4										
6										
9										
Locknut for CK tube connector										
	MCK Metal type	-	-	-	-	3, 4, 6, 9, 13	-	15		
	MCK-...-KU Polymer design	-	-	-	-	3, 4, 6, 9	-	15		

Quick connectors CK/CX

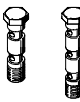
Product range overview

FESTO

Design	Design	Type	Connection D1		Tubing I.D.	Free of copper, PTFE and silicone	→ Page/Internet		
			M thread	G thread					
Multiple distributor	Ring piece with 2 seals								
		LK Metal type	M5	–	3, 4	–	16		
			–	G $\frac{1}{8}$	3, 4, 6				
				G $\frac{1}{4}$	4, 6				
		G $\frac{3}{8}$		6					
		LK-...-KU Polymer design	–	G $\frac{1}{8}$	4, 6			–	16
			–	G $\frac{1}{4}$	4, 6				
	–			–	–				
	Ring piece with 2 seals								
		TK Metal type	M5	–	3, 4	–	17		
			–	G $\frac{1}{8}$	3, 4, 6				
				G $\frac{1}{4}$	4, 6				
G $\frac{3}{8}$		6							
TK-...-KU Polymer design		–	G $\frac{1}{8}$	4, 6	–			17	
		–	G $\frac{1}{4}$	4, 6					
	–		–	–					
Hollow bolt with 2 ring pieces									
	VT-...-2 2 ring pieces	M5	G $\frac{1}{8}$	3, 4, 6	–	18			
		–	G $\frac{1}{4}$	4, 6					
			G $\frac{3}{8}$	6					
	VT-...-3 3 ring pieces		M5	G $\frac{1}{8}$			3, 4, 6	–	18
		–	G $\frac{1}{4}$	4, 6					
			G $\frac{3}{8}$	6					
For metal braided hoses PX									
Straight	Quick connector								
		ACX	–	G $\frac{1}{8}$	4	–	19		
				G $\frac{1}{4}$	6				
				G $\frac{3}{8}$	9				
	Quick connector								
		CX	–	G $\frac{1}{8}$	4, 6	–	19		
				G $\frac{1}{4}$	4, 6				
				G $\frac{3}{8}$	9				
	L-shape	Elbow quick connector							
			LCX	–	G $\frac{1}{8}$	4	–	20	
G $\frac{1}{4}$					6				
G $\frac{3}{8}$					9				
T-shape	T quick connector								
		TCX	–	G $\frac{1}{8}$	4	–	20		
				G $\frac{1}{4}$	6				
				G $\frac{3}{8}$	9				

Quick connectors ACK

Technical data

Quick connector ACK

Female thread with sealing ring

Material:

Blue anodised aluminium

Free of copper and PTFE

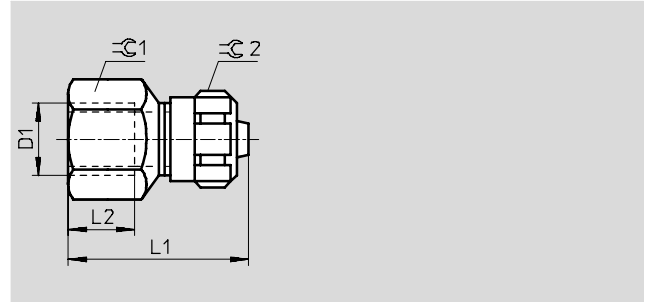

Dimensions and ordering data									
Connection	Nominal size	Tubing I.D.	L1	L2	⌀C1	⌀C2	Part No.	Type	PU*
D1	[mm]								
G $\frac{1}{8}$	2.4	3	23.9	9	13	8	5 664	ACK- $\frac{1}{8}$ -PK-3	10
	3.4	4	27	9	13	12	3 714	ACK- $\frac{1}{8}$ -PK-4	10
	5.3	6	27	9	13	14	7 842	ACK- $\frac{1}{8}$ -PK-6	10
G $\frac{1}{4}$	3.4	4	30	12	17	12	3 713	ACK- $\frac{1}{4}$ -PK-4	10
	5.3	6	30	12	17	14	3 712	ACK- $\frac{1}{4}$ -PK-6	10
G $\frac{3}{8}$	5.3	6	31	12	19	14	3 711	ACK- $\frac{3}{8}$ -PK-6	10
	8	9	37.4	15	19	19	3 710	ACK- $\frac{3}{8}$ -PK-9	1
G $\frac{1}{2}$	12	13	40.2	15	27	24	4 099	ACK- $\frac{1}{2}$ -PK-13	1

* Packaging unit quantity

Quick connectors CK

Technical data



Quick connector CK

Male thread with sealing ring

Material:

M thread: Steel, aluminium

G thread: Blue anodised aluminium

Free of copper and PTFE

Certification: Germanischer Lloyd

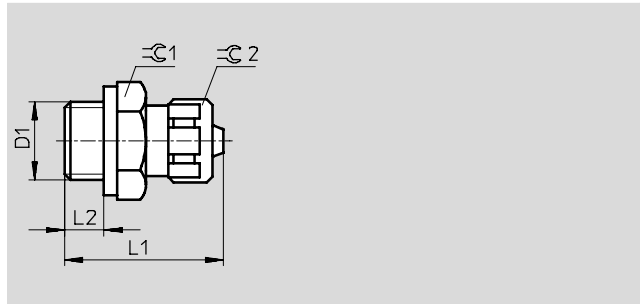

Quick connector CK...-KU

Male thread with moulded-on sealing ring

Material:

Polyacetate

Free of copper and PTFE

Conforms to RoHS

Pressure range: 0 ... 10 bar

Temperature range: -10 ... +60 °C

Certification: Germanischer Lloyd

Dimensions and ordering data									
Connection	Nominal size	Tubing I.D.	L1	L2	∅C	∅C1	Part No.	Type	PU*
D1	[mm]								
Metal design									
M5	2.0	3	19.3	3.8	7	8	3 561	CK-M5-PK-3	10
	2.9	4	21.5	3.8	10	-	3 562	CK-M5-PK-4	10
G ¹ / ₈	2.0	3	21.6	4.9	13	8	3 563	CK- ¹ / ₈ -PK-3	10
	2.9	4	24.7	4.9	13	12	2 027	CK- ¹ / ₈ -PK-4	10
	4.9	6	24.8	4.9	13	14	2 028	CK- ¹ / ₈ -PK-6	10
G ¹ / ₄	2.9	4	27.2	5.8	17	12	2 029	CK- ¹ / ₄ -PK-4	10
	4.9	6	27.3	5.8	17	14	2 030	CK- ¹ / ₄ -PK-6	10
	8	9	30.6	5.8	17	19	2 031	CK- ¹ / ₄ -PK-9	10
G ³ / ₈	4.9	6	28.3	6.8	19	14	2 032	CK- ³ / ₈ -PK-6	10
	8	9	31.6	6.8	19	19	2 033	CK- ³ / ₈ -PK-9	10
	11.7	13	33.2	6.8	24	24	4 097	CK- ³ / ₈ -PK-13	10
G ¹ / ₂	11.7	13	34.7	8.5	24	24	4 098	CK- ¹ / ₂ -PK-13	1
Polymer design									
G ¹ / ₈	2.4	3	22.2	6.5	13	8	6 253	CK- ¹ / ₈ -PK-3-KU	10
	3.4	4	25.3	6.5	13	12	6 254	CK- ¹ / ₈ -PK-4-KU	10
	4.4	6	25.4	6.5	13	14	6 255	CK- ¹ / ₈ -PK-6-KU	10
G ¹ / ₄	3.4	4	28.5	8.5	17	12	6 256	CK- ¹ / ₄ -PK-4-KU	10
	5.3	6	28.6	8.5	17	14	6 257	CK- ¹ / ₄ -PK-6-KU	10
	7.3	9	31.9	8.5	17	19	6 258	CK- ¹ / ₄ -PK-9-KU	10
G ³ / ₈	5.3	6	31	10.5	19	14	6 460	CK- ³ / ₈ -PK-6-KU	10
	8	9	34.5	10.5	19	19	6 468	CK- ³ / ₈ -PK-9-KU	10

* Packaging unit quantity

Bulkhead quick connectors QCK

Technical data

Bulkhead quick connector QCK
Female thread with sealing ring

Material:
Blue anodised aluminium/steel
Free of copper and PTFE

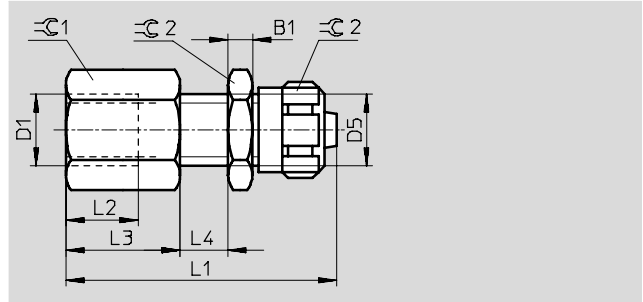

Dimensions and ordering data														
Connection	Nominal size	Tubing I.D.	B1	D5	L1	L2	L3	L4	ø1	ø2	ø3	Part No.	Type	PU*
D1	[mm]							max.						
M5	2.4	3	3.2	M6x0.75	31	6	10	8	7	8	10	9 424	QCK-M5-PK-3-B	1
G ¹ / ₈	3.4	4	3.5	M10x1	40	8	13.5	10	13	12	13	9 425	QCK- ¹ / ₈ -PK-4-B	1
G ¹ / ₄	5.3	6	4	M12x1	45	12	18	10	17	14	17	9 426	QCK- ¹ / ₄ -PK-6-B	1
G ³ / ₈	8	9	5	M16x1	50	12	18.6	10	19	19	22	9 427	QCK- ³ / ₈ -PK-9-B	1

* Packaging unit quantity

Bulkhead quick connectors SCK

Technical data

FESTO

Bulkhead quick connector SCK

Material:
Blue anodised aluminium/steel
Free of copper and PTFE

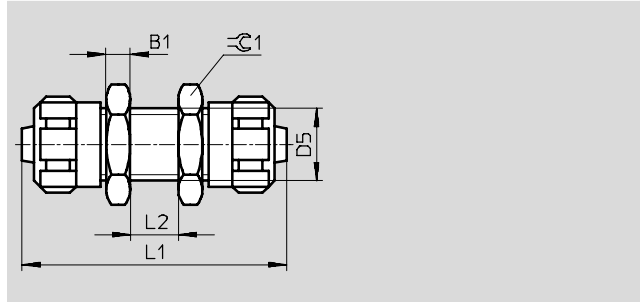

Bulkhead quick connector SCK-...-KU with moulded-on sealing ring

Material:
Polyacetate
Free of copper and PTFE
Conforms to RoHS

Pressure range: 0 ... 10 bar
Temperature range: -10 ... +60 °C

Dimensions and ordering data									
Nominal size	Tubing I.D.	B1	D5	L1	L2 max.	⌀C1	Part No.	Type	PU*
[mm]									
Aluminium design									
2.4	3	3.2	M6x0.75	34	8	10	9 420	SCK-PK-3	1
3.4	4	3.5	M10x1	43	10	13	9 421	SCK-PK-4	1
5.3	6	4	M12x1	44	10	17	9 422	SCK-PK-6	1
8	9	5	M16x1	53	10	22	9 423	SCK-PK-9	1
Polymer design									
2.4	3	5	M10x1 ¹⁾	41	10	13	9 387	SCK-PK-3-KU	10
3.4	4	5	M10x1	46		13	9 388	SCK-PK-4-KU	10
5.3	6	6	M12x1	48		17	9 389	SCK-PK-6-KU	10
8	9	7	M16x1	57		22	9 390	SCK-PK-9-KU	1

* Packaging unit quantity

1) Installation diameter varies from aluminium version

End caps CV

Technical data

End cap CV

for sealing barbed fittings and connectors for polymer tubing

Material:

Polyurethane

Free of copper and PTFE

Conforms to RoHS

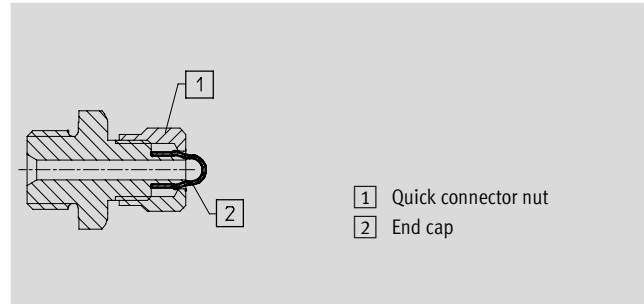

Dimensions and ordering data				
Tubing I.D.	Weight/piece [g]	Part No.	Type	PU*
3	0.001	6 213	CV-PK-3-B	10
4	0.001	6 214	CV-PK-4-B	10
6	0.001	6 215	CV-PK-6-B	10
9	0.002	6 216	CV-PK-9-B	10

Operating conditions (permissible static pressure)								
Type	CV-PK-3-B ... CV-PK-6-B						CV-PK-9-B	
Operating pressure [bar]	10	10	8	7	6	6	4	
Ambient temperature [°C]	-35	+20	+40	+60	+80	+60	+80	

* Packaging unit quantity

Elbow quick connectors GCK

Technical data

Elbow quick connector GCK-...-KU

Material:
Polyacetate
Free of copper and PTFE
Conforms to RoHS

Pressure range: 0 ... 10 bar
Temperature range: -10 ... +60 °C

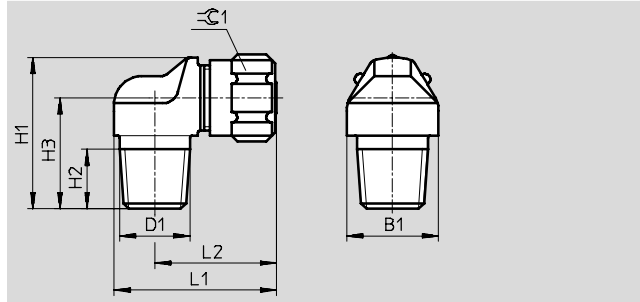

Dimensions and ordering data												
Connection D1	Nominal size [mm]	Tubing I.D.	B1	H1	H2	H3	L1	L2	$\sqrt{\text{C}}1$	Part No.	Type	PU*
R $\frac{1}{8}$	2.9	4	13	22.5	8	16.5	26.5	20.5	20.5	6 267	GCK- $\frac{1}{8}$ -PK-4-KU	10
	4.9	6	17	24.5	8	17.5	28.5	21.5	21.5	6 268	GCK- $\frac{1}{8}$ -PK-6-KU	10
R $\frac{1}{4}$	2.9	4	17	25.5	11	19.5	30	22.5	22.5	6 269	GCK- $\frac{1}{4}$ -PK-4-KU	10
	4.9	6	17	27.5	11	20.5	30	22.5	22.5	6 270	GCK- $\frac{1}{4}$ -PK-6-KU	10
R $\frac{3}{8}$	4.9	6	19	28.5	10.5	21	34	24.5	24.5	6 271	GCK- $\frac{3}{8}$ -PK-6-KU	10
	8	9	19	33.5	10.5	23.5	37.2	27.7	27.7	6 272	GCK- $\frac{3}{8}$ -PK-9-KU	10

* Packaging unit quantity

Elbow quick connectors LCK

Technical data

Elbow quick connector LCK
rotatable with 2 sealing rings

Material:
Die-cast zinc
Free of copper and PTFE

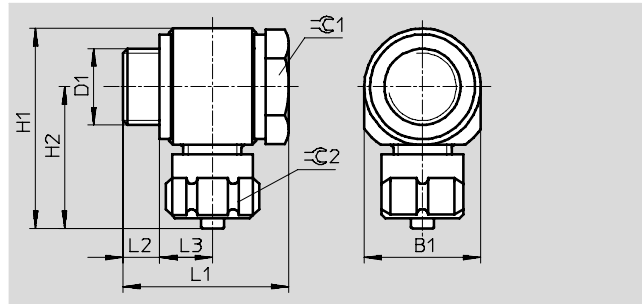

Elbow quick connector LCK-...-KU
rotatable with moulded-on sealing ring

Material:
Polyacetate
Free of copper and PTFE

Pressure range: 0 ... 10 bar
Temperature range: -10 ... +60 °C

Dimensions and ordering data													
Connection	Nominal size	Tubing I.D.	B1	H1	H2	L1	L2	L3	≙C1	≙C2	Part No.	Type	PU*
D1	[mm]												
Die-cast zinc design													
M5	2.4	3	10	21.1	16.1	17.2	3.8	5.2	7	7	4 468	LCK-M5-PK-3	10
	2.4	4	11	21.1	16.1	18	3.8	5.6	7	7	4 562	LCK-M5-PK-4	10
G3/8	2	3	16	27.1	19.1	21.1	4.9	6.1	13	13	4 136	LCK-3/8-PK-3	10
	2.9	4	16	30.2	22.2	27.1	4.9	9.1	13	13	4 469	LCK-3/8-PK-4	10
	4.9	6	16	30.3	22.3	27.1	4.9	9.1	13	13	4 470	LCK-3/8-PK-6	10
G1/4	2.9	4	20	34.2	24.2	28.1	5.7	9.2	17	17	4 471	LCK-1/4-PK-4	10
	4.9	6	20	34.3	24.3	28.1	5.5	9.3	17	17	4 472	LCK-1/4-PK-6	10
	8	9	20	37.6	27.6	33.3	5.7	11.8	17	17	11 452	LCK-1/4-PK-9	10
G3/8	4.9	6	25	39.3	26.8	30.3	6.7	9.3	22	22	4 473	LCK-3/8-PK-6	1
	8	9	25	42.6	30.1	35.3	6.7	11.8	22	22	4 474	LCK-3/8-PK-9	1
G1/2	11.7	13	30	49.2	34.2	46.6	7.9	16.85	27	27	4 100	LCK-1/2-PK-13	1
Polymer design													
G3/8	3.4	4	16	30.5	22.5	27.5	7.1	8.25	13	13	6 259	LCK-3/8-PK-4-KU	10
	5.3	6	16	30.5	22.5	27.5	7.1	8.25	13	13	6 260	LCK-3/8-PK-6-KU	10
G1/4	3.4	4	20	34.5	24.5	28.5	8.1	8.25	17	17	6 261	LCK-1/4-PK-4-KU	10
	5.3	6	20	34.5	24.5	28.5	8.1	8.25	17	17	6 262	LCK-1/4-PK-6-KU	10

* Packaging unit quantity

Elbow quick connectors LCKN

Technical data

FESTO

Elbow quick connector LCKN
rotatable with sealing ring OL...

Material:
Die-cast zinc/aluminium with sealing ring

Pressure range: -0.9 ... 16 bar
Temperature range: -20 ... +80 °C

Note: Cannot be used as a rotary distributor.

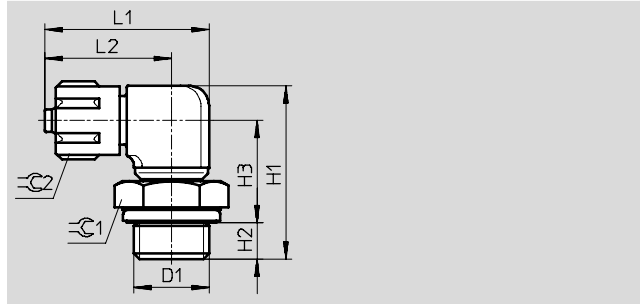

Dimensions and ordering data												
Connection	Nominal size	Tubing I.D.	H1	H2	H3	L1	L2	G1	G2	Part No.	Type	PU*
D1	[mm]											
M5	1.7	3	22.2	3.55	15.15	20.1	16.1	7	8	164 995	LCKN-M5-PK-3	10
	2.6	4	24.3	3.55	15.75	23.2	19.2	7	-	164 996	LCKN-M5-PK-4	10
G ¹ / ₈	1.7	3	24.6	4.7	15.9	25.4	18.9	13	8	164 997	LCKN- ¹ / ₈ -PK-3	10
	2.6	4	27	4.7	16.3	28.5	22	13	12	164 998	LCKN- ¹ / ₈ -PK-4	10
	4.6	6	30.3	4.7	18.6	28.6	22.1	13	14	164 999	LCKN- ¹ / ₈ -PK-6	10
G ¹ / ₄	2.6	4	29.5	5.8	17.7	28.5	22	17	12	165 000	LCKN- ¹ / ₄ -PK-4	10
	4.6	6	32.8	5.8	20.0	28.6	22.1	17	14	165 001	LCKN- ¹ / ₄ -PK-6	10
G ³ / ₈	4.6	6	33.8	6.0	20.8	28.6	22.1	19	14	165 002	LCKN- ³ / ₈ -PK-6	1

* Packaging unit quantity

T quick connectors TCK

Technical data

FESTO

T quick connector TCK rotatable

Material:
Die-cast zinc with 2 sealing rings
Thread G $\frac{3}{8}$ and G $\frac{1}{2}$ aluminium, blue
anodised
Free of copper and PTFE

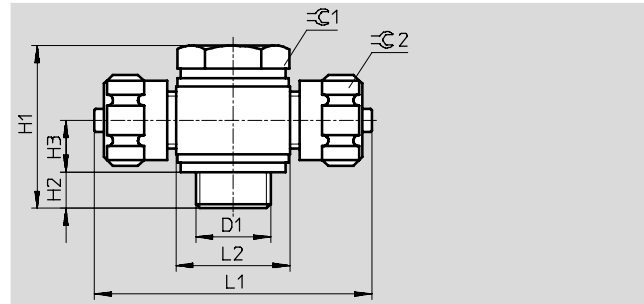

T quick connector TCK-...-KU

rotatable with moulded-on sealing
ring

Material:
Polyacetate
Free of copper and PTFE

Pressure range: 0 ... 10 bar
Temperature range: -10 ... +60 °C

Dimensions and ordering data												
Connection D1	Nominal size [mm]	Tubing I.D.	H1	H2	H3	L1	L2	≙C1	≙C2	Part No.	Type	PU*
Die-cast zinc design												
M5	2	3	17.2	3.8	5.2	32.2	10	7	8	4 484	TCK-M5-PK-3	10
	2	4	18	3.8	5.6	39.4	11	7	8	4 563	TCK-M5-PK-4	10
G $\frac{3}{8}$	2	3	21.1	4.9	6.1	38.2	16	13	8	4 137	TCK- $\frac{3}{8}$ -PK-3	10
	2.9	4	27.1	4.9	9.1	44.4	16	13	12	4 485	TCK- $\frac{3}{8}$ -PK-4	10
	4.9	6	27.1	4.9	9.1	44.6	16	13	14	4 486	TCK- $\frac{3}{8}$ -PK-6	10
G $\frac{1}{4}$	2.9	4	28.1	5.7	9.2	48.4	20	17	12	4 487	TCK- $\frac{1}{4}$ -PK-4	10
	4.9	6	28.1	5.5	9.3	48.6	20	17	14	4 488	TCK- $\frac{1}{4}$ -PK-6	10
Aluminium design												
G $\frac{3}{8}$	4.9	6	30.3	6.7	9.3	53.6	25	22	14	4 489	TCK- $\frac{3}{8}$ -PK-6	1
	8	9	35.3	6.7	11.8	60.2	25	22	14	4 490	TCK- $\frac{3}{8}$ -PK-9	1
G $\frac{1}{2}$	11.7	13	46.6	7.9	16.9	68.4	30	27	24	4 101	TCK- $\frac{1}{2}$ -PK-13	1
Polymer design												
G $\frac{1}{8}$	3.4	4	27.5	7.1	8.25	45	16	13	12	6 263	TCK- $\frac{1}{8}$ -PK-4-KU	10
	5.3	6	27.5	7.1	8.25	45	16	13	14	6 264	TCK- $\frac{1}{8}$ -PK-6-KU	10
G $\frac{1}{4}$	3.4	4	28.5	8.1	8.25	49	20	17	12	6 265	TCK- $\frac{1}{4}$ -PK-4-KU	10
	5.3	6	28.5	8.1	8.25	49	20	17	14	6 266	TCK- $\frac{1}{4}$ -PK-6-KU	10

* Packaging unit quantity

T quick connectors FCK

Technical data

FESTO

T-distributor FCK-...-KU

Material:

Polymer

Free of copper and PTFE

Conforms to RoHS

Pressure range: 0 ... 10 bar

Temperature range: -10 ... +60 °C

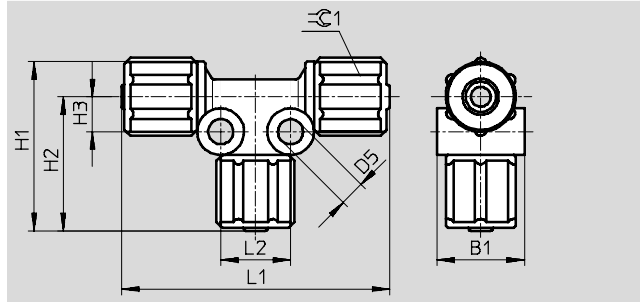

Dimensions and ordering data												
Tubing I.D.	Nominal size [mm]	B1	D5	H1	H2	H3	L1	L2	$\pm\varnothing 1$	Part No.	Type	PU*
3	2.4	11	4.3	22.9	18.9	5	37.8	10	8	6 273	FCK-3-PK-3-KU	10
4	3.4	15	4.3	29	23	6	46	12	12	6 274	FCK-3-PK-4-KU	10
6	5.3	18	4.3	30.1	23.1	6	46.2	12	14	6 275	FCK-3-PK-6-KU	10
9	8	22	4.3	37	28.5	7.1	53.8	13	19	6 276	FCK-3-PK-9-KU	10

* Packaging unit quantity

Locknuts MCK

Technical data

Locknut MCK
for tube connectors

Material:
Blue anodised aluminium
Free of copper and PTFE
Conforms to RoHS

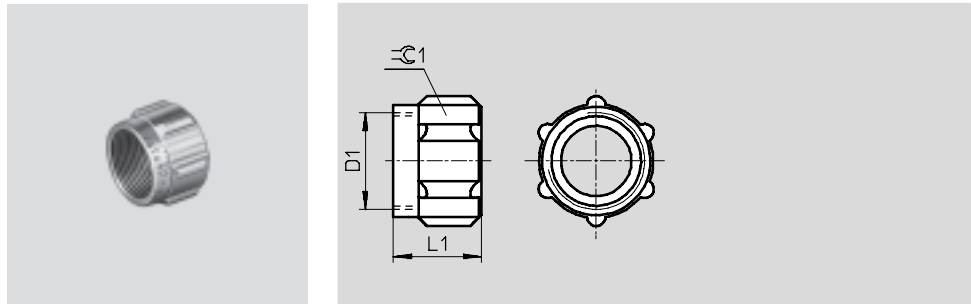

Locknut MCK-...-KU
for tube connectors

Material:
Polymer design
Free of copper and PTFE
Conforms to RoHS

Dimensions and ordering data						
Tubing I.D.	D1	L1	$\approx \text{C}1$	Part No.	Type	PU*
Aluminium design						
3	M6x0.75	8.5	8	205 254	MCK-PK-3	1
4	M10x1	11	12	2 965	MCK-PK-4 ¹⁾	1
4	M8x1	9.5	–	205 257	MCK-PK-4-R ²⁾	1
6	M12x1	11	14	2 966	MCK-PK-6	1
9	M16x1	14.4	19	2 967	MCK-PK-9	1
13	M22x1	18	24	206 504	MCK-PK-13	1
Polymer design						
3	M6x0.75	9.5	8	211 289	MCK-PK-3-KU	1
4	M10x1	12.5	12	211 291	MCK-PK-4-KU ¹⁾	1
6	M12x1	12.5	14	211 292	MCK-PK-6-KU	1
9	M16x1	16	19	211 293	MCK-PK-9-KU	1

* Packaging unit quantity

1) except for connectors CK-M5-PK-4, LCK-M5-PK-4, TCK-M5-PK-4

2) for connectors CK-M5-PK-4, LCK-M5-PK-4, TCK-M5-PK-4

Multiple distributors

Technical data

FESTO

Hollow bolt VT with ring piece LK
(one outlet connection)

Materials:

Hollow bolt: Galvanised steel

Ring piece LK: Die-cast zinc

Ring piece LK-...-KU: Polymer

Free of copper and PTFE

Certification:

Ring piece LK: Germanischer Lloyd

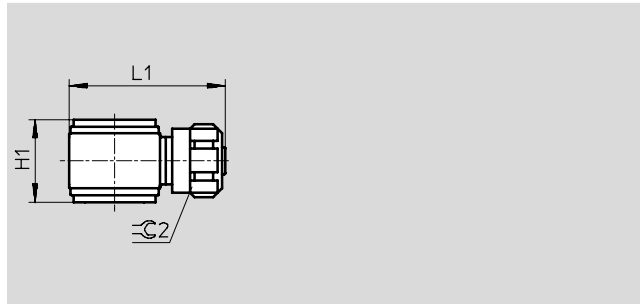

Ordering data				Dimensions → 18			
Hollow bolt				Ring piece			
Pneumatic connection	No. of ring pieces	Part No.	Type	Pneumatic connection	Part No.	Type	PU*
Die-cast zinc design							
M5	2	206 145	VT-M5-2 ³⁾	for 3 mm tubing	4 475	LK-M5-PK-3 ¹⁾	10
	3	4 594	VT-M5-3 ³⁾				
G ¹ / ₈	2	4 593	VT- ¹ / ₈ -2-PK-3 ³⁾	for 3 mm tubing	4 597	LK- ¹ / ₈ -PK-3 ¹⁾	10
	3	4 595	VT- ¹ / ₈ -3-PK-3				
G ¹ / ₈	2	206 146	VT- ¹ / ₈ -2 ³⁾	for 4 mm tubing	4 476	LK- ¹ / ₈ -PK-4 ¹⁾	10
	3	4 596	VT- ¹ / ₈ -3 ³⁾				
G ¹ / ₈	2	206 146	VT- ¹ / ₈ -2 ³⁾	for 6 mm tubing	4 477	LK- ¹ / ₈ -PK-6 ¹⁾	10
	3	4 596	VT- ¹ / ₈ -3 ³⁾				
G ¹ / ₄	2	206 147	VT- ¹ / ₄ -2 ³⁾	for 4 mm tubing	4 478	LK- ¹ / ₄ -PK-4 ¹⁾	10
	3	2 335	VT- ¹ / ₄ -3 ³⁾				
G ¹ / ₄	2	206 147	VT- ¹ / ₄ -2 ³⁾	for 6 mm tubing	4 479	LK- ¹ / ₄ -PK-6 ¹⁾	10
	3	2 335	VT- ¹ / ₄ -3 ³⁾				
G ³ / ₈	2	206 148	VT- ³ / ₈ -2 ³⁾	for 6 mm tubing	4 480	LK- ³ / ₈ -PK-6 ¹⁾	1
	3	2 336	VT- ³ / ₈ -3 ³⁾				
Polymer design							
G ¹ / ₈	2	206 146	VT- ¹ / ₈ -2 ³⁾	for 4 mm tubing	6 280	LK- ¹ / ₈ -PK-4-KU ²⁾ 3)	10
	3	4 596	VT- ¹ / ₈ -3 ³⁾				
G ¹ / ₈	2	206 146	VT- ¹ / ₈ -2 ³⁾	for 6 mm tubing	6 281	LK- ¹ / ₈ -PK-6-KU ²⁾ 3)	10
	3	4 596	VT- ¹ / ₈ -3 ³⁾				
G ¹ / ₄	2	206 147	VT- ¹ / ₄ -2 ³⁾	for 4 mm tubing	6 282	LK- ¹ / ₄ -PK-4-KU ²⁾ 3)	10
	3	2 335	VT- ¹ / ₄ -3 ³⁾				
G ¹ / ₄	2	206 147	VT- ¹ / ₄ -2 ³⁾	for 6 mm tubing	6 283	LK- ¹ / ₄ -PK-6-KU ²⁾ 3)	10
	3	2 335	VT- ¹ / ₄ -3 ³⁾				

* Packaging unit quantity

1) with 2 sealing rings

2) with moulded-on sealing ring, pressure range 0...10 bar, temperature range -10...+60 °C

3) Conforms to RoHS

Multiple distributors

Technical data

FESTO

Hollow bolt VT with ring piece TK (2 outlet connections)

Materials:

Hollow bolt: Galvanised steel

Ring piece TK: Die-cast zinc

Ring piece TK-...-KU: Polymer

Free of copper and PTFE

Certification:

Ring piece TK: Germanischer Lloyd

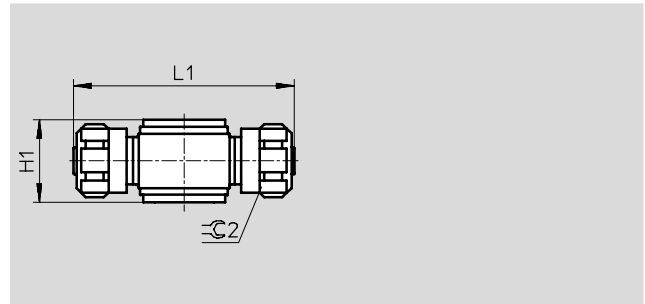

Ordering data				Dimensions → 18			
Hollow bolt				Ring piece			
Pneumatic connection	No. of ring pieces	Part No.	Type	Pneumatic connection	Part No.	Type	PU*
Die-cast zinc design							
M5	2	206 145	VT-M5-2 ³⁾	for 3 mm tubing	4 491	TK-M5-PK-3 ¹⁾	10
	3	4 594	VT-M5-3 ³⁾		4 491	TK-M5-PK-3 ¹⁾	10
G ¹ / ₈	2	4 593	VT- ¹ / ₈ -2-PK-3 ³⁾	for 3 mm tubing	4 598	TK- ¹ / ₈ -PK-3 ¹⁾	10
	3	4 595	VT- ¹ / ₈ -3-PK-3	for 4 mm tubing	4 492	TK- ¹ / ₈ -PK-4 ¹⁾	10
	2	206 146	VT- ¹ / ₈ -2 ³⁾				
	3	4 596	VT- ¹ / ₈ -3 ³⁾	for 6 mm tubing	4 493	TK- ¹ / ₈ -PK-6 ¹⁾	10
	2	206 146	VT- ¹ / ₈ -2 ³⁾				
	3	4 596	VT- ¹ / ₈ -3 ³⁾				
G ¹ / ₄	2	206 147	VT- ¹ / ₄ -2 ³⁾	for 4 mm tubing	4 494	TK- ¹ / ₄ -PK-4 ¹⁾	10
	3	2 335	VT- ¹ / ₄ -3 ³⁾	for 6 mm tubing	4 495	TK- ¹ / ₄ -PK-6 ¹⁾	10
	2	206 147	VT- ¹ / ₄ -2 ³⁾				
	3	2 335	VT- ¹ / ₄ -3 ³⁾				
G ³ / ₈	2	206 148	VT- ³ / ₈ -2 ³⁾		4 496	TK- ³ / ₈ -PK-6 ¹⁾	1
Polymer design							
G ¹ / ₈	2	206 146	VT- ¹ / ₈ -2 ³⁾	for 4 mm tubing	6 284	TK- ¹ / ₈ -PK-4-KU ²⁾ 3)	10
	3	4 596	VT- ¹ / ₈ -3 ³⁾	for 6 mm tubing	6 285	TK- ¹ / ₈ -PK-6-KU ²⁾ 3)	10
	2	206 146	VT- ¹ / ₈ -2 ³⁾				
	3	4 596	VT- ¹ / ₈ -3 ³⁾				
G ¹ / ₄	2	206 147	VT- ¹ / ₄ -2 ³⁾	for 4 mm tubing	6 286	TK- ¹ / ₄ -PK-4-KU ²⁾ 3)	10
	3	2 335	VT- ¹ / ₄ -3 ³⁾	for 6 mm tubing	6 287	TK- ¹ / ₄ -PK-6-KU ²⁾ 3)	10
	2	206 147	VT- ¹ / ₄ -2 ³⁾				
	3	2 335	VT- ¹ / ₄ -3 ³⁾				

* Packaging unit quantity

1) with 2 sealing rings

2) with moulded-on sealing ring, pressure range 0...10 bar, temperature range -10...+60 °C

3) Conforms to RoHS

Multiple distributors

Technical data



Multiple distributor

consisting of:

- Hollow bolt VT and ring piece LK
→ 16

or

- Hollow bolt VT and ring piece TK
→ 17

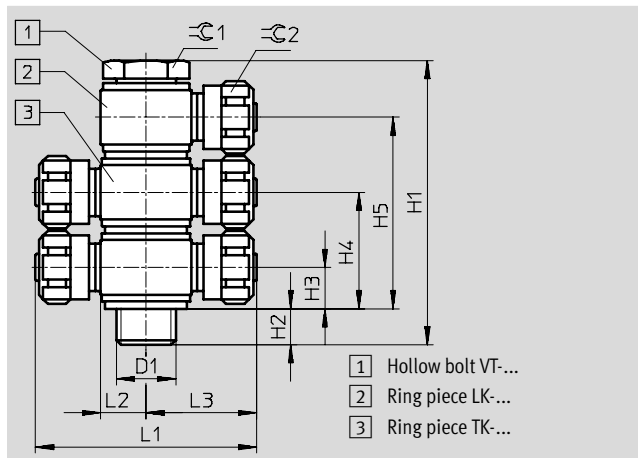

Dimensions														
Connection D1	Hollow bolt Type	Ring piece Type	H1	H2	H3	H4	H5	L1	L2	L3	⌀G1	⌀G2		
M5	VT-M5-2	LK-M5-PK-3	27.3	4	5.2	15.1	-	-	5	16.1	7	8		
		TK-M5-PK-3						32.2	-					
	VT-M5-3	LK-M5-PK-3	37.1	3.9	5.2	15.1	25	-	5	16.1	7	8		
		TK-M5-PK-3						32.2	-					
G ¹ / ₈	VT- ¹ / ₈ -2-PK-3	LK- ¹ / ₈ -PK-3	31.8	5	6.1	16.7	-	-	8	19.1	13	8		
		TK- ¹ / ₈ -PK-3						38.2	-					
	VT- ¹ / ₈ -3-PK-3	LK- ¹ / ₈ -PK-3	42.4	5	6.1	16.7	27.3	-	8	19.1	13	8		
		TK- ¹ / ₈ -PK-3						38.2	-					
	VT- ¹ / ₈ -2	LK- ¹ / ₈ -PK-4	44	5.2	9.1	25.7	-	-	8	22.2	13	12		
								TK- ¹ / ₈ -PK-4	44.4				-	
		LK- ¹ / ₈ -PK-6						-	8	22.3			14	
								TK- ¹ / ₈ -PK-6	44.6					-
	VT- ¹ / ₈ -3	LK- ¹ / ₈ -PK-4	60.8	5.4	9.1	25.7	42.3	-	8	22.2	13	12		
								TK- ¹ / ₈ -PK-4	44.4					-
		LK- ¹ / ₈ -PK-6						-	8	22.3			14	
								TK- ¹ / ₈ -PK-6	44.6					-
G ¹ / ₄	VT- ¹ / ₄ -2	LK- ¹ / ₄ -PK-4	44.7	6.1	9.2	25.4	-	-	10	24.2	17	12		
		TK- ¹ / ₄ -PK-4						48.4	-					
		LK- ¹ / ₄ -PK-6		5.7	9.3	25.7		-	10	24.3		14		
				TK- ¹ / ₄ -PK-6	48.6	-								
	VT- ¹ / ₄ -3	LK- ¹ / ₄ -PK-4	61.9	6.1	9.2	25.4	41.6	-	10	24.2	17		12	
								TK- ¹ / ₄ -PK-4	48.4					-
		LK- ¹ / ₄ -PK-6		5.5	9.3	25.7	42.1	-	10	24.3		14		
				TK- ¹ / ₄ -PK-6	48.6	-								
	G ³ / ₈	VT- ³ / ₈ -2	LK- ³ / ₈ -PK-6	46.9	6.9	9.3	25.7	-	-	12.5	26.8		22	14
			TK- ³ / ₈ -PK-6						53.6	-				
VT- ³ / ₈ -3		LK- ³ / ₈ -PK-6	63.1	6.7	9.3	25.7	42.1		-	12.5	26.8	22		14
									TK- ³ / ₈ -PK-6	53.6				

Quick connectors ACX/CX, metal braided hose

Technical data

Quick connector ACX

Female thread with sealing ring for metal braided hose PX

Material:

Anodised aluminium

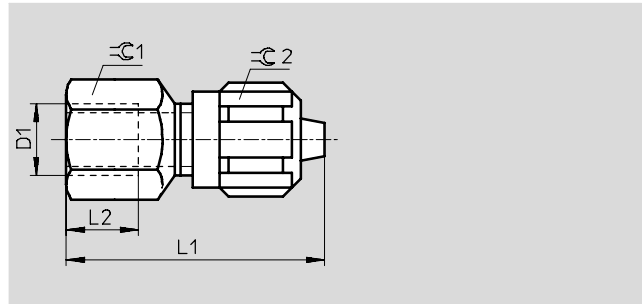

Dimensions and ordering data									
Connection D1	Nominal size [mm]	Tubing I.D.	L1	L2	∅C1	∅C2	Part No.	Type	PU*
G ¹ / ₈	3.5	4	35	10	13	12	4 032	ACX- ¹ / ₈ -PX-4	1
G ¹ / ₄	5	6	43	12	17	14	4 033	ACX- ¹ / ₄ -PX-6	1
G ³ / ₈	8	9	54	15	22	19	4 034	ACX- ³ / ₈ -PX-9	1

* Packaging unit quantity

Quick connector CX

Male thread with sealing ring for metal braided hose PX

Material:

Anodised aluminium

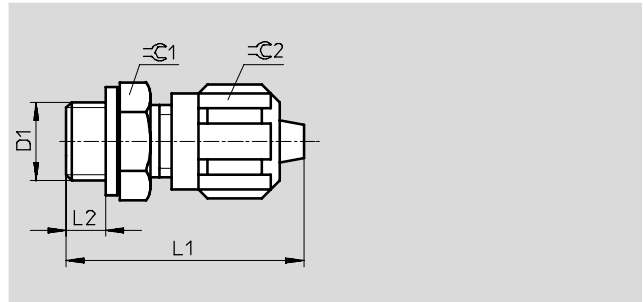

Dimensions and ordering data									
Connection D1	Nominal size [mm]	Tubing I.D.	L1	L2	∅C1	∅C2	Part No.	Type	PU*
G ¹ / ₈	3.5	4	31.5	4.9	13	12	4 035	CX- ¹ / ₈ -PX-4	10
	5	6	36.5	4.9	13	14	4 453	CX- ¹ / ₈ -PX-6	10
G ¹ / ₄	3.5	4	34	5.8	17	12	4 454	CX- ¹ / ₄ -PX-4	10
	5	6	39	5.8	17	14	4 036	CX- ¹ / ₄ -PX-6	10
G ³ / ₈	8	9	47	6.8	22	19	4 037	CX- ³ / ₈ -PX-9	1

* Packaging unit quantity

Quick connectors LCX/TCX, metal braided hose

Technical data

Elbow quick connector LCX

rotatable with 2 sealing rings for metal braided hose PX

Material:

Anodised aluminium

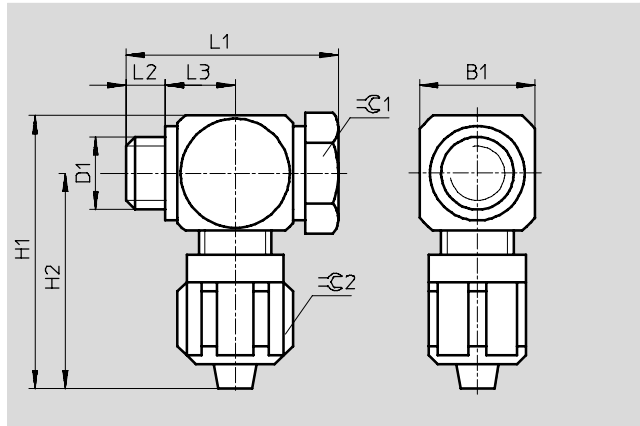

Dimensions and ordering data													
Connection D1	Nominal size [mm]	Tubing I.D.	B1	L1	L2	L3	H1	H2	≅C1	≅C2	Part No.	Type	PU*
G ¹ / ₈	3.5	4	16	27.1	4.7	9.2	39.5	31.5	13	14	4 041	LCX- ¹ / ₈ -PX-4	1
G ¹ / ₄	5	6	20	34.3	5.7	11.8	46	36	17	17	4 042	LCX- ¹ / ₄ -PX-6	1
G ³ / ₈	8	9	25	41.3	6.7	14.3	58	45.5	22	22	4 043	LCX- ³ / ₈ -PX-9	1

* Packaging unit quantity

T quick connector TCX

rotatable with 2 sealing rings for metal braided hose PX

Material:

Anodised aluminium

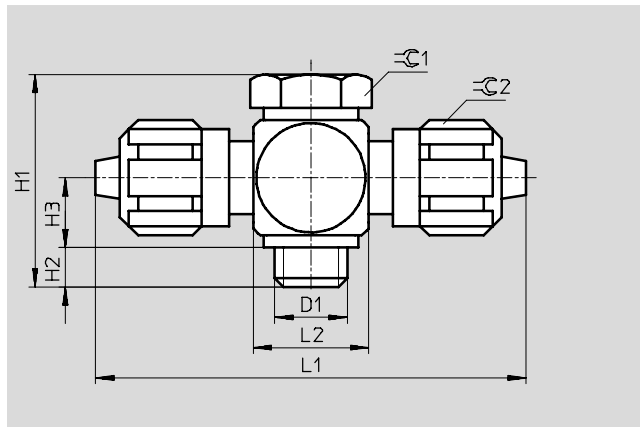

Dimensions and ordering data												
Connection D1	Nominal size [mm]	Tubing I.D.	H1	H2	H3	L1	L2	≅C1	≅C2	Part No.	Type	PU*
G ¹ / ₈	3.5	4	27.1	4.7	9.2	63	16	13	14	4 044	TCX- ¹ / ₈ -PX-4	1
G ¹ / ₄	5	6	34.3	5.7	11.8	72	20	17	17	4 045	TCX- ¹ / ₄ -PX-6	1
G ³ / ₈	8	9	41.3	6.7	14.3	91	25	22	22	4 046	TCX- ³ / ₈ -PX-9	1

* Packaging unit quantity