







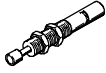

- Adjustable or self-adjusting
- With linear or progressive characteristic
- Stop elements:
combination of cushioning and
end-position sensing
- Specified types in accordance with ATEX
directive for potentially explosive
atmospheres
→ www.festo.com/en/ex

Cushioning components

Product range overview

FESTO

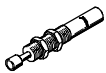
Function	Type	Variant	Brief description	Area of application	
Shock absorber	Adjustable				
	YSR		<ul style="list-style-type: none"> Hydraulic shock absorber with pressure-controlled flow control function Hardness of cushioning adjustable Oil refillable (with the exception of YSR-8-8-D) 	–	
	DYEF		<ul style="list-style-type: none"> Mechanical shock absorber with flexible rubber buffer Hardness of cushioning adjustable Flexible rubber buffer allows a defined metallic end position Full external mounting thread plus internal hex 	• Mini slide DGSL	
	Self-adjusting				
	YSR-C		<ul style="list-style-type: none"> Hydraulic shock absorber with displacement-controlled flow control function Rapidly increasing cushioning force curve Short cushioning stroke Suitable for rotary drives Maintenance-free Full external mounting thread 	<ul style="list-style-type: none"> Swivel module DSM Linear drive DGPL Linear drive DGC Swivel/linear unit DSL Linear unit SLE 	
	DYSC		<ul style="list-style-type: none"> Hydraulic shock absorber with displacement-controlled flow control function Rapidly increasing cushioning force curve Short cushioning stroke Suitable for rotary drives Maintenance-free Full external mounting thread plus internal hex 	• Swivel module DSM-B	
	YSRW		<ul style="list-style-type: none"> Hydraulic shock absorber with displacement-controlled flow control function Gradually increasing cushioning force curve Long cushioning stroke Suitable for low-vibration operation Short cycle times possible Maintenance-free Full external mounting thread plus spanner flat 	<ul style="list-style-type: none"> Linear drive DGC Linear module HMP, HMPL Handling module HSP 	
	DYSW		<ul style="list-style-type: none"> Hydraulic shock absorber with displacement-controlled flow control function Gradually increasing cushioning force curve Long cushioning stroke Suitable for low-vibration operation Short cycle times possible Maintenance-free Full external mounting thread plus internal hex 	• Mini slide DGSL	
	Stop element	Self-adjusting			
		YSRWJ		<ul style="list-style-type: none"> Cushioning with self-adjusting, progressive hydraulic shock absorber (YSRW) Gradually increasing cushioning force curve Adjustable cushioning stroke End position sensing with proximity sensor SME/SMT-8 Precision end position adjustment Stop elements YSRWJ can be used for a wide variety of applications in handling and assembly technology 	• Linear module HMPL
Hydraulic cushioning cylinder	Adjustable				
	YDR		<ul style="list-style-type: none"> Energy is dissipated by displacing oil through a flow control valve A built-in compression spring returns the piston rod to the initial position Linear, adjustable Suitable for slow feed speeds in the range of 0.1 m/s 	–	

Cushioning components

Product range overview

Size [mm]	Stroke [mm]	Energy absorption per stroke [J]	Position sensing	Free of copper, PTFE and silicone	→ Page/Internet
Adjustable					
8, 12, 16, 20, 25, 32	8, 12, 20, 25, 40, 60	4 ... 380	-	-	4
M4, M5, M6, M8, M10, M12, M14, M16	1.7; 2.8; 3.1; 3.4; 3.7; 4.2; 5; 4.8	0.005 ... 0.25	-	■	8
Self-adjusting					
4, 5, 7, 8, 10, 12, 16, 20, 25, 32	4, 5, 8, 10, 12, 20, 25, 40, 60	0.6 ... 380	-	■ Size 4 ... 20	12
5, 7, 8, 12	5, 8, 12	1 ... 10	-	■	12
5, 7, 8, 10, 12, 16, 20	8, 10, 14, 17, 20, 26, 34	1.3 ... 70	-	■	20
4, 5, 7, 8, 10, 12	6, 8, 10, 14, 17, 20	0.8 ... 12	-	■	24
Self-adjusting					
5, 7, 8	8, 10, 14	1 ... 3	■	-	28
Adjustable					
16, 20, 25, 32	20, 25, 40, 60	32 ... 384	-	-	32

Shock absorbers YSR

Peripherals overview and type codes

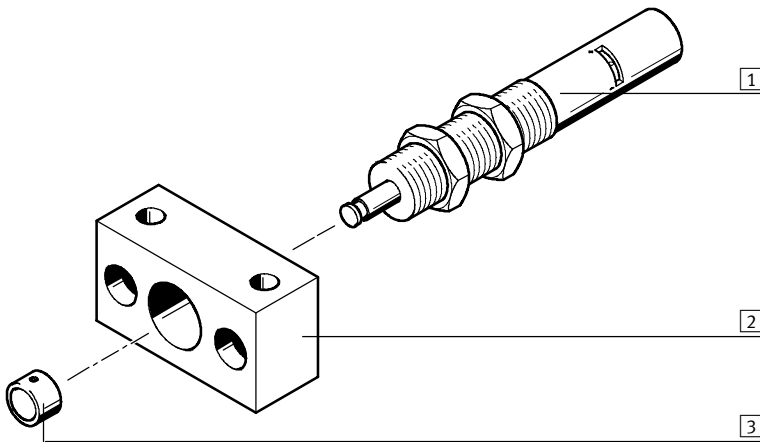

Accessories			
	Type	Brief description	→ Page/Internet
1	Shock absorber YSR	Hydraulic shock absorber with adjustable cushioning characteristic	5
2	Mounting flange YSRF	Mounting option for shock absorber	36
3	Buffer YSRP	For the protection of piston rod	38
-	Oil gun YSR-OEP	For topping up oil	38
-	Special oil OFSB-1	Replacement oil	38

	YSR	-	12	-	12	-	
Type							
YSR	Shock absorber						
Size							
Stroke [mm]							
Buffer							
D	With buffer						



Shock absorbers YSR

Technical data

FESTO

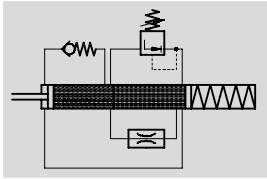
Function



-  Size
8 ... 32 mm
-  Stroke length
8 ... 60 mm



General technical data						
Size	8	12	16	20	25	32
Stroke [mm]	8	12	20	25	40	60
Mode of operation	Hydraulic shock absorbers with return spring Single acting, pushing					
Cushioning	Adjustable					
Cushioning length [mm]	8	12	20	25	40	60
Type of mounting	With locknut					
Impact velocity [m/s]	0.1 ... 3					
Mounting position	Any					
Product weight [g]	40	120	240	420	860	1,600
Ambient temperature [°C]	-10 ... +80					
Corrosion resistance class CRC ¹⁾	2					

- 1) Corrosion resistance class 2 to Festo standard 940 070
Components subject to moderate corrosion stress. Externally visible parts with primarily decorative surface requirements which are in direct contact with a normal industrial environment or media such as coolants or lubricating agents

Reset times [s]						
Size	8	12	16	20	25	32
Short ¹⁾	≤ 0.4					
Long ²⁾	≤ 1					

- 1) Piston rod retracted for short period ≤ 30 s
2) Piston rod retracted for longer period ≤ 6 h

Forces [N]						
Size	8	12	16	20	25	32
Max. stop force in end positions	400	900	1,600	2,500	4,000	6,400
Resetting force	3	25	20	25	30	35

Energies [J]						
Size	8	12	16	20	25	32
Max. energy absorption per stroke	4	10.8	32	62.5	160	380
Max. energy absorption per hour	24,000	77,000	130,000	180,000	293,000	483,000
Max. residual energy	0.01	0.05	0.16	0.32	0.8	2

Shock absorbers YSR

Technical data

FESTO

Materials

Sectional view

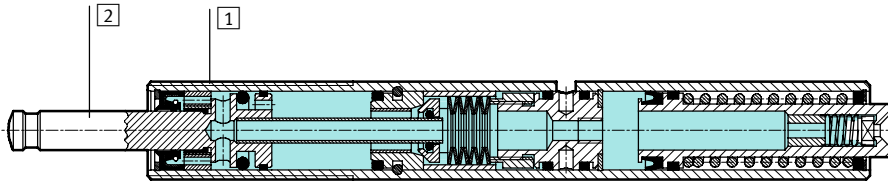

Shock absorber

1	Housing	Galvanised steel
2	Piston rod	High-alloy steel
-	Seals	Nitrile rubber, polyurethane
-	Note on materials	Free of copper and PTFE
		Conforms to RoHS

Selection graph for shock absorbers with infinitely adjustable cushioning YSR

Impact velocity dependent on mass m

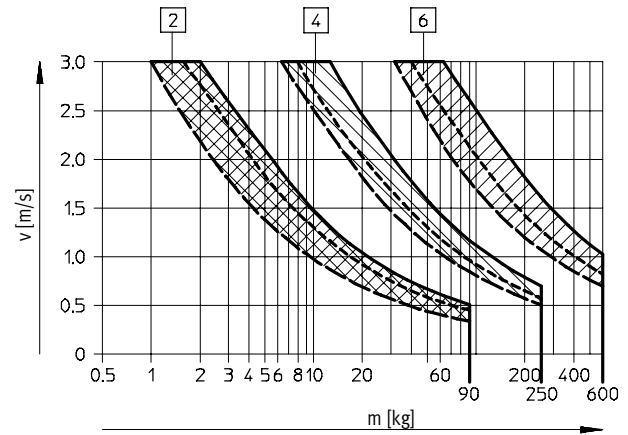
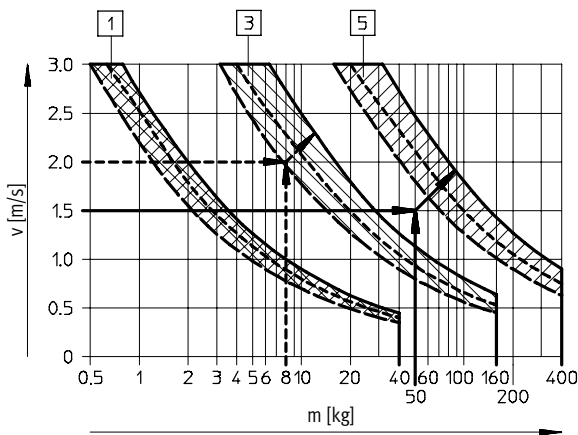

Three force curves are shown for each shock absorber. Interim values must be calculated by averaging.

The arrows relate to the examples starting on page → 42.

- 1 YSR-8-8-D
- 2 YSR-12-12
- 3 YSR-16-20

- 4 YSR-20-25
- 5 YSR-25-40
- 6 YSR-32-60

Shock absorber	Max. stop force in end position	Force A = <u> </u>	Force A = <u> - - -</u>	Force A = <u> - - - -</u>
YSR-8-8-D	400 N	0 N	100 N	200 N
YSR-12-12	900 N	0 N	200 N	500 N
YSR-16-20	1,600 N	0 N	500 N	800 N
YSR-20-25	2,500 N	0 N	800 N	1,200 N
YSR-25-40	4,000 N	0 N	1 200 N	2,000 N
YSR-32-60	6,400 N	0 N	2,000 N	3,000 N

Shock absorbers YSR

Technical data

FESTO

Dimensions

Download CAD data → www.festo.com

YSR-8-8-D

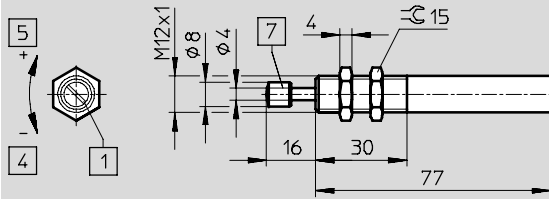

- 1 Cushioning adjustment
- 4 - Less cushioning
- 5 + More cushioning
- 7 Buffer (included in scope of delivery)

YSR ...

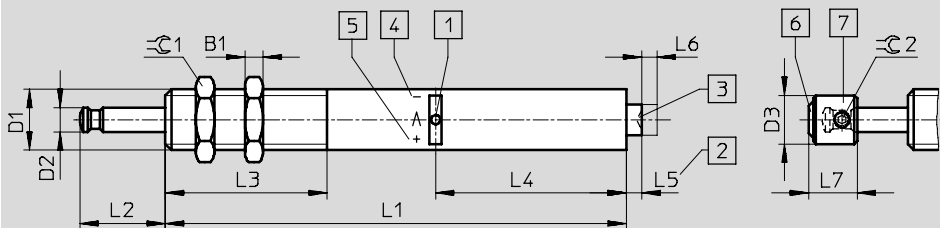

- 1 Cushioning adjustment
- 2 Oil reservoir
- 3 Oil top-up facility
- 4 - Less cushioning
- 5 + More cushioning
- 6 Polyurethane insert
- 7 Buffer YSRP (to be ordered separately)

Size	B1	D1	D2	D3	L1	L2	L3
[mm]			Ø	Ø			
8	-	-	-	-	-	-	-
12	5	M15x1	6	12	119	18	36
16	6	M20x1.25	8	16	151	28	53
20	8	M24x1.25	10	20	174	35	60
25	10	M30x1.5	12	25	227	52	80
32	12	M37x1.5	15	32	275	75	108

Size	L4	L5	L6	L7	≈C1	≈C2	Max. tightening torque ≈C1 [Nm]
[mm]		max.		±0.4			
8	-	-	-	-	-	-	5
12	52.5	5	3	10	19	2	20
16	62.5	5	5	13.5	24	2.5	35
20	72.5	6	6	17	30	3	60
25	89.8	9	10	20.5	36	4	80
32	106.3	13	15	26	46	4	100

Ordering data

Size	Part No.	Type
[mm]		
8	189 980	YSR-8-8-D
12	10 867	YSR-12-12
16	10 868	YSR-16-20
20	10 869	YSR-20-25
25	10 870	YSR-25-40
32	10 871	YSR-32-60

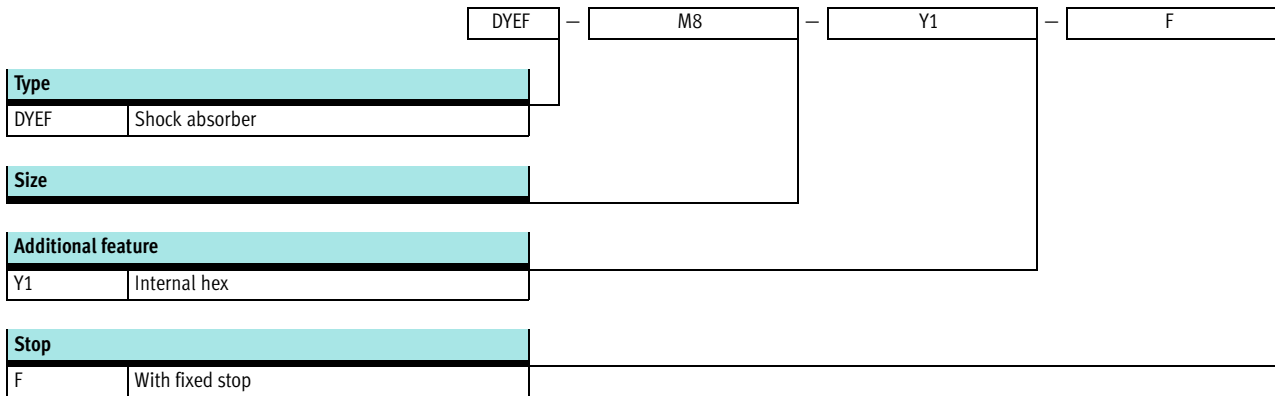

Shock absorbers DYE F

Type codes



Shock absorbers DYEF

Technical data

-  Size
4 ... 16
-  Stroke length
1.7 ... 5 mm



General technical data								
Size	M4	M5	M6	M8	M10	M12	M14	M16
Stroke [mm]	1.7	2.8	3.1	3.4	3.7	4.2	5	4.8
Mode of operation	Elastomer cushioning with metallic fixed stop							
Cushioning	Adjustable							
Cushioning length [mm]	1.7	2.8	3.1	3.4	3.7	4.2	5	4.8
Type of mounting	With lock nut							
Max. impact velocity [m/s]	0.8							
Mounting position	Any							
Product weight [g]	1.6	2.9	5.1	11.9	19.7	39.6	77.3	104
Ambient temperature [°C]	0 ... +60							
Corrosion resistance class CRC ¹⁾	2							

1) Corrosion resistance class 2 to Festo standard 940 070
Components subject to moderate corrosion stress. Externally visible parts with primarily decorative surface requirements which are in direct contact with a normal industrial environment or media such as coolants or lubricating agents

Forces [N]								
Size	M4	M5	M6	M8	M10	M12	M14	M16
Min. input force ¹⁾	15	30	40	60	70	100	150	180

1) This is the minimum force that must be applied so that the shock absorber is pushed exactly into the retracted end position. This value is reduced correspondingly in the event of an extended external end position or a reduction in the cushioning stroke

Energies [J]								
Size	M4	M5	M6	M8	M10	M12	M14	M16
Max. energy absorption per stroke	0.005	0.02	0.03	0.04	0.06	0.12	0.2	0.25

Mass range [kg]								
Size	M4	M5	M6	M8	M10	M12	M14	M16
Mass range up to	0.15	0.25	0.4	0.6	1.2	1.8	3	5

Shock absorbers DYE

Technical data

Materials	
Shock absorber	
Adjustable sleeve	Stainless steel
Setting piece	Stainless steel
Cushioning rubber	Nitrile rubber
Note on materials	Copper, PTFE and silicone-free
	Conforms to RoHS

Impact velocity dependent on mass m

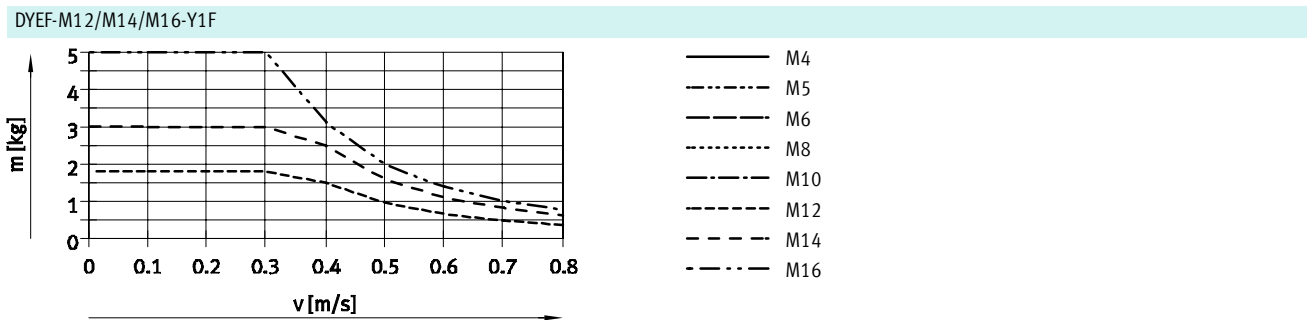
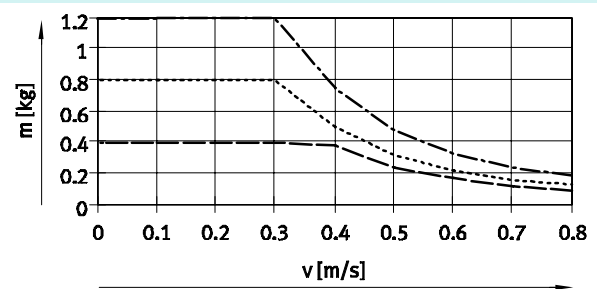
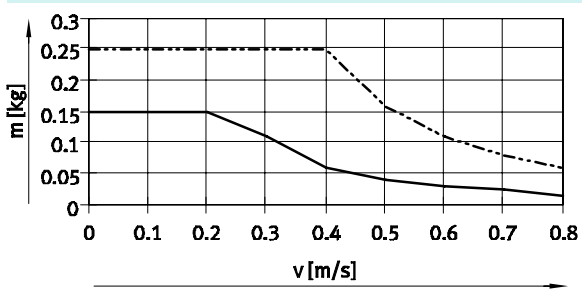

Shock absorbers DYEF

Technical data

FESTO

Dimensions

Download CAD data → www.festo.com

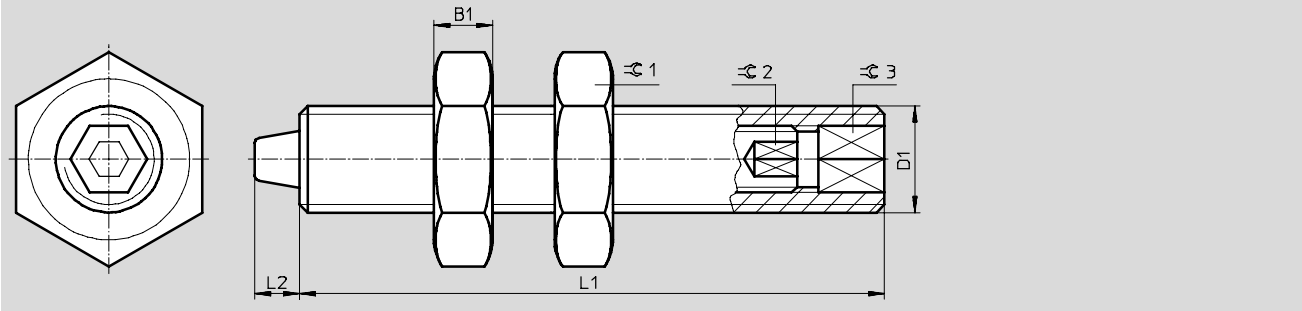

Size [mm]	B1	D1	L1	L2 min. +0.3	1	2	3	Max. tightening torque 1 [Nm]
M4	2.2	M4x0.5	22	1.7	7	1.3	2.5	0.5
M5	2.7	M5x0.5	26	2.8	8	1.5	3	0.8
M6	2.5	M6x0.5	30	3.1	8	2	4	1
M8	3	M8x1	38	3.4	10	2.5	5	2
M10	3.5	M10x1	41	3.7	13	3	6	3
M12	4	M12x1	54	4.2	15	4	8	5
M14	5	M14x1	72	5	17	4	8	8
M16	5	M16x1	75	4.8	19	5	10	20

Ordering data

Size [mm]	Part No.	Type
M4	548 370	DYEF-M4-Y1F
M5	548 371	DYEF-M5-Y1F
M6	548 372	DYEF-M6-Y1F
M8	548 373	DYEF-M8-Y1F
M10	548 374	DYEF-M10-Y1F
M12	548 375	DYEF-M12-Y1F
M14	548 376	DYEF-M14-Y1F
M16	548 377	DYEF-M16-Y1F

Shock absorbers YSR-C

Peripherals overview and type codes

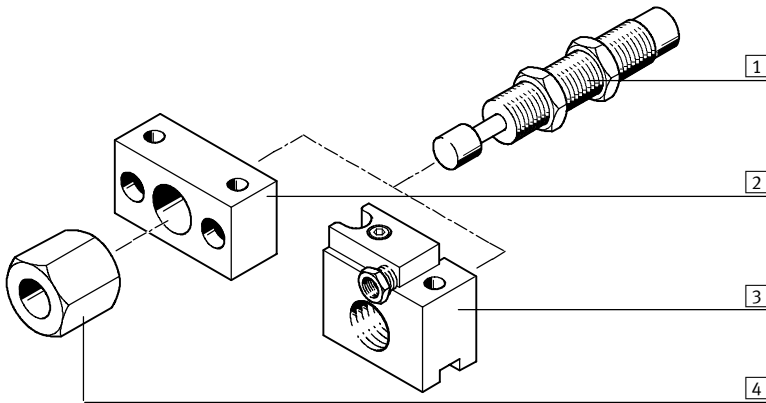

Accessories			
	Type	Brief description	→ Page/Internet
1	Shock absorber YSR-C	Hydraulic shock absorber with rapidly increasing cushioning force curve	13
2	Mounting flange YSRF	Mounting option for shock absorber	36
3	Mounting flange YSRF-S	Mounting option for shock absorber with attached stop sleeve and position sensing	37
4	Stop limiters YSRA	Stroke limiter for shock absorber	38



	YSR	-	16	-	20	-	C
Type							
YSR	Shock absorber						
Size [mm]							
Stroke [mm]							
Cushioning function							
C	Self-adjusting						

Shock absorbers YSR-C

Technical data

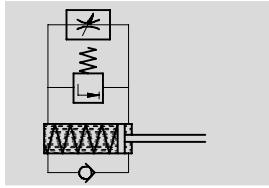
Function



-  Size
4 ... 32 mm
-  Stroke length
4 ... 60 mm



General technical data										
Size	4	5	7	8	10	12	16	20	25	32
Stroke [mm]	4	5	5	8	10	12	20	25	40	60
Mode of operation	Hydraulic shock absorbers with return spring Single acting, pushing									
Cushioning	Self-adjustable									
Cushioning length [mm]	4	5	5	8	10	12	20	25	40	60
Type of mounting	With locknut									
Impact velocity [m/s]	0.05 ... 2		0.05 ... 3							
Mounting position	Any									
Product weight [g]	5	9	18	30	50	70	140	240	600	1,250
Ambient temperature [°C]	-10 ... +80									
Corrosion resistance class CRC ¹⁾	2									

1) Corrosion resistance class 2 to Festo standard 940 070
Components subject to moderate corrosion stress. Externally visible parts with primarily decorative surface requirements which are in direct contact with a normal industrial environment or media such as coolants or lubricating agents

Reset time [s]										
Size	4	5	7	8	10	12	16	20	25	32
Reset time ¹⁾	≤ 0.2								≤ 0.4	≤ 0.5

1) The specified technical data refers to ambient temperature. At higher temperatures in the 80 °C range, the max. mass and the cushioning work must be reduced by 50% approx. At -10 °C, the reset time may be up to 1 second

Forces [N]										
Size	4	5	7	8	10	12	16	20	25	32
Min. insertion force ¹⁾	6.5	7.5	10	18	25	35	60	100	140	160
Max. stop force ²⁾ in end positions	100	200	300	500	700	1,000	2,000	3,000	4,000	6,000
Min. resetting force ³⁾	0.7	0.9	1.2	2.5	3.5	5	6	10	14	20

1) This is the minimum force that must be applied so that the shock absorber is pushed exactly into the retracted end position. This value is reduced correspondingly in the event of an extended external end-position
2) If the max. stop force is exceeded, a fixed stop (e.g. YSRA) 0.5 mm must be fitted before the end of stroke
3) This is the maximum force which may act upon the piston rod, allowing for full extension of the shock absorber (e.g. protruding stem)

Energies [J]										
Size	4	5	7	8	10	12	16	20	25	32
Max. energy absorption per stroke	0.6	1	2	3	6	10	30	60	160	380
Max. energy absorption per hour	5,600	8,000	12,000	18,000	26,000	36,000	64,000	92,000	150,000	220,000
Max. residual energy	0.006	0.01		0.02	0.03	0.05	0.16	0.32	0.8	2

Mass range [kg]										
Size	4	5	7	8	10	12	16	20	25	32
Permissible mass range up to	1.2	1.5	5	15	25	45	90	120	200	400

Shock absorbers YSR-C

Technical data

FESTO

Materials

Sectional view

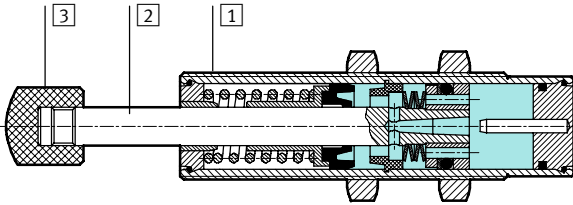

Piston Ø		4	5	7	8	10	12	16	20	25	32	
1	Housing	Brass, nickel-plated				Galvanised steel						
2	Piston rod	High-alloy steel										
3	Buffer	Polyacetate				Polyamide				Steel with polyurethane		
-	Seals	Nitrile rubber, polyurethane										
-	Note on materials	Free of copper, PTFE and silicone									-	
		Conforms to RoHS										

Selection graph for self-adjusting shock absorbers YSR-C

Impact velocity dependent on mass m

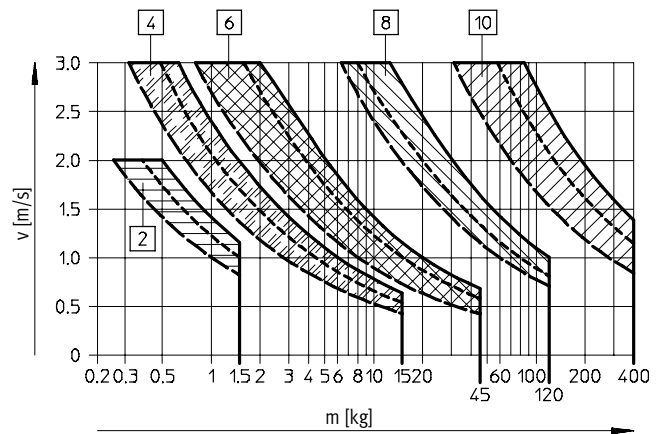
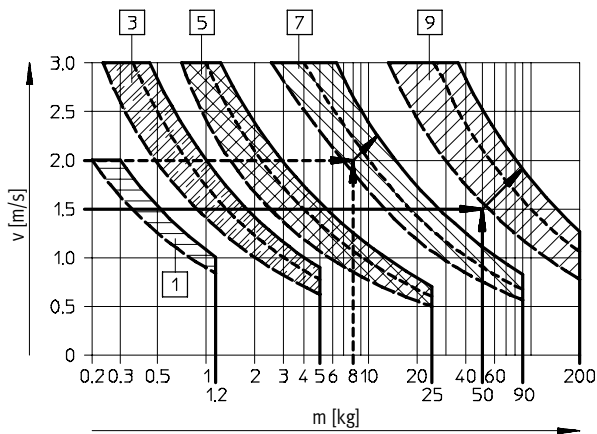

Three force curves are shown for each shock absorber. Interim values must be calculated by averaging. The

arrows relate to the examples starting on page → 42.

- | | | | |
|---|-------------|----|-------------|
| 1 | YSR-4-4-C | 5 | YSR-12-12-C |
| 2 | YSR-5-5-C | 6 | YSR-16-20-C |
| 2 | YSR-7-5-C | 7 | YSR-20-25-C |
| 3 | YSR-8-8-C | 8 | YSR-25-40-C |
| 4 | YSR-10-10-C | 10 | YSR-32-60-C |

Shock absorber	Max. stop force in end position	Force A = <u> </u>	Force A = <u> </u>	Force A = <u> </u>
YSR-4-4-C	100 N	0 N	-	50 N
YSR-5-5-C	200 N	0 N	50 N	100 N
YSR-7-5-C	300 N	0 N	100 N	200 N
YSR-8-8-C	500 N	0 N	100 N	200 N
YSR-10-10-C	700 N	0 N	150 N	300 N
YSR-12-12-C	1,000 N	0 N	200 N	500 N
YSR-16-20-C	2,000 N	0 N	500 N	800 N
YSR-20-25-C	3,000 N	0 N	800 N	1,200 N
YSR-25-40-C	4,000 N	0 N	1,200 N	2,500 N
YSR-32-60-C	6,000 N	0 N	2,000 N	4,000 N

Shock absorbers YSR-C

Technical data

FESTO

Dimensions

Download CAD data → www.festo.com

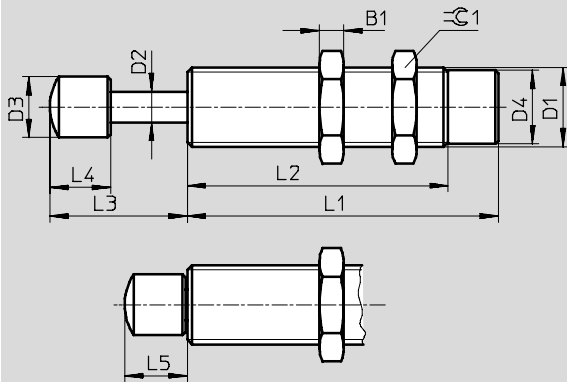

Size	B1	D1	D2	D3	D4	L1
[mm]			Ø	Ø	Ø	±0.1
4	2,5	M6x0,5	2	3,8 ±0,1	5,3 ±0,05	28,5
5	3	M8x1	2,5	5 ±0,1	6,7 ±0,05	29
7	3,5	M10x1	3	6 ±0,1	8,6 ±0,05	34
8	4	M12x1	4	8 ±0,2	10,4 ±0,1	46
10	5	M14x1	5	10 ±0,2	12,4 ±0,1	55
12	5	M16x1	6	12 ±0,2	14,5 ±0,1	64
16	6	M22x1,5	8	16 ±0,2	20 ±0,1	86
20	8	M26x1,5	10	20 ±0,2	24 ±0,1	104
25	10	M30x1,5	12	25 ±0,2	28 ±0,1	152
32	12	M37x1,5	15	32 ±0,2	35 ±0,1	207

Size	L2	L3	L4	L5	≈C1	Max. tightening torque ≈C1
[mm]	±0,3					[Nm]
4	18,5	8,3 +0,6/-0,3	4 ±0,1	4,3 +0,35/-0,25	8	1
5	19	10,8 +0,6/-0,3	5,5 ±0,1	5,8 +0,55/-0,25	10	2
7	23	12,3 +0,7/-0,35	7 ±0,2	7,3 +0,55/-0,25	13	3
8	33	16,3 +0,7/-0,35	8 ±0,2	8,3 +0,55/-0,25	15	5
10	42	20,5 +0,7/-0,35	10 ±0,2	10,5 +0,55/-0,25	17	8
12	51	24,5 +0,7/-0,35	12 ±0,2	12,5 +0,55/-0,25	19	20
16	69	36,5 +0,7/-0,35	16 ±0,2	16,5 +0,55/-0,25	27	35
20	87	45,5 +0,7/-0,35	20 ±0,2	20,5 +0,55/-0,25	32	60
25	125	61,5 +1,25/-0,75	20,5 ±0,4	21,5 +0,95/-0,55	36	80
32	179	87 +1,25/-0,75	26 ±0,4	27 +0,95/-0,55	46	100

Ordering data

Size	Part No.	Type
[mm]		
4	540 060	YSR-4-4-C ¹⁾
5	158 981	YSR-5-5-C ¹⁾
7	160 272	YSR-7-5-C ¹⁾
8	34 571	YSR-8-8-C ¹⁾
10	191 199	YSR-10-10-C ¹⁾
12	34 572	YSR-12-12-C ¹⁾
16	34 573	YSR-16-20-C ¹⁾
20	34 574	YSR-20-25-C ¹⁾
25	160 273	YSR-25-40-C
32	160 274	YSR-32-60-C

1) Free of copper, PTFE and silicone

Shock absorbers DYSC

Type codes

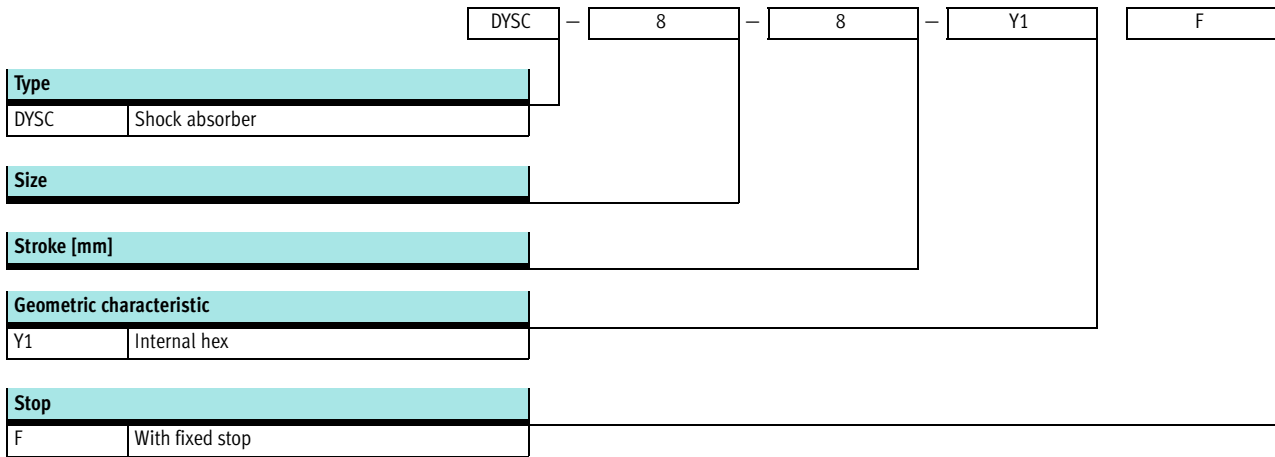

Shock absorbers DYSC

Technical data

Function

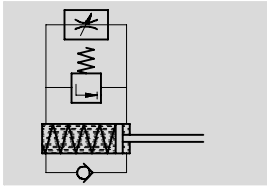

- \varnothing - Size
5 ... 12
- | - Stroke length
5 ... 12 mm



General technical data				
Size	5	7	8	12
Stroke [mm]	5	5	8	12
Mode of operation	Hydraulic shock absorber with spring return Single acting, pushing			
Cushioning	Self-adjusting, hard characteristic curve			
Cushioning length [mm]	5	5	8	12
Type of mounting	With lock nut			
Impact velocity [m/s]	0.05 ... 2		0.05 ... 3	
Mounting position	Any			
Product weight [g]	9	17	36	81
Ambient temperature [°C]	-10 ... +80			
Corrosion resistance class CRC ¹⁾	2			

- 1) Corrosion resistance class 2 to Festo standard 940 070
Components subject to moderate corrosion stress. Externally visible parts with primarily decorative surface requirements which are in direct contact with a normal industrial environment or media such as coolants or lubricating agents

Reset time [s]				
Size	5	7	8	12
Reset time ¹⁾	≤ 0.2			

- 1) The specified technical data refers to ambient temperature. At higher temperatures in the 80 °C range, the max. mass and the cushioning work must be reduced by 50% approx. At -10 °C, the reset time may be up to 1 second

Forces [N]				
Size	5	7	8	12
Min. insertion force ¹⁾	7.5	10	18	35
Max. stop force ²⁾ in end positions	200	300	500	1 000
Min. resetting force ³⁾	0.9	1.2	2.5	5

- 1) This is the minimum force that must be applied so that the shock absorber is pushed exactly into the retracted end position. This value is reduced correspondingly in the event of an extended external end position
2) If the max. stop force is exceeded, a fixed stop (e.g. YSRA) 0.5 mm must be fitted before the end of stroke
3) This is the maximum force which may act upon the piston rod, allowing for full extension of the shock absorber (e.g. protruding stem)

Energies [J]				
Size	5	7	8	12
Max. energy absorption per stroke	1	2	3	10
Max. energy absorption per hour	8,000	12,000	18,000	36,000
Max. residual energy	0.01		0.02	0.05

Mass range [kg]				
Size	5	7	8	12
Mass range up to	1.5	5	15	45

Shock absorbers DYSC

Technical data

FESTO

Materials				
Size	5	7	8	12
Housing	Brass, nickel-plated			Galvanised steel
Piston rod	High-alloy steel			
Buffer	Polyacetate			
Seals	Nitrile rubber			
Note on materials	Copper, PTFE and silicone-free			
	Conforms to RoHS			

Selection graph for self-adjusting shock absorbers DYSC

Impact velocity dependent on mass m

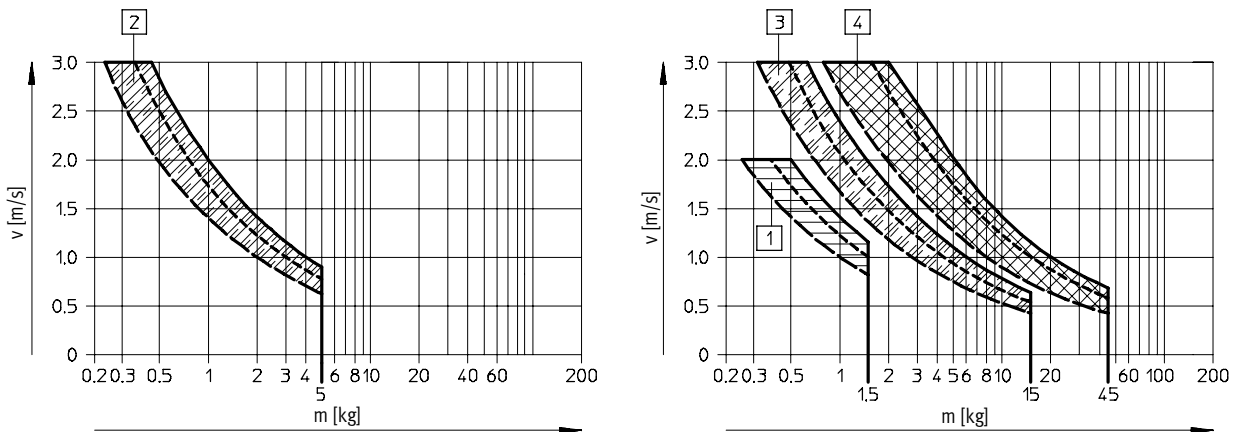

Three force curves are shown for each shock absorber. Interim values must be calculated by averaging.

1 DYSC-5-5-Y1F 3 DYSC-8-8-Y1F
2 DYSC-7-5-Y1F 4 DYSC-12-12-Y1F

Shock absorber	Max. stop force in end position	Force A =	Force A =	Force A =
DYSC-5-5-Y1F	200 N	0 N	50 N	100 N
DYSC-7-5-Y1F	300 N	0 N	100 N	200 N
DYSC-8-8-Y1F	500 N	0 N	100 N	200 N
DYSC-12-12-Y1F	1,000 N	0 N	200 N	500 N

Shock absorbers DYSC

Technical data

FESTO

Dimensions

Download CAD data → www.festo.com

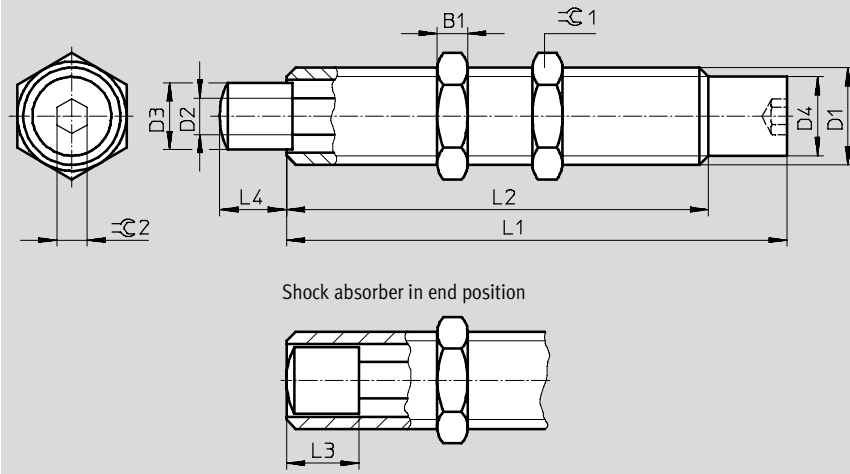

Size	B1	D1	D2 ∅	D3 ∅	D4 ∅	L1	L2
[mm]						±0.1	+0.3/-0.2
5	3	M8x1	2.5	4.7 ±0.05	6.7 ±0.05	38.6	28.4
7	3.5	M10x1	3	6 ±0.1	8.6 ±0.05	45.15	34.15
8	4	M12x1	4	7 ±0.1	10.4 ±0.1	59.05	46.05
12	5	M16x1	6	11 ±0.1	14.5 ±0.1	82.5	69.5

Size	L3 ¹⁾	L4	≡C1	≡C2	Max. tightening torque ≡C1
[mm]					[Nm]
5	5.5	5 +0.32/-0.28	10	2.5	2
7	7	5 +0.37/-0.28	13	3	3
8	8	8 +0.42/-0.33	15	4	5
12	12	12 +0.50/-0.35	19	5	20

1) Buffer length

Ordering data

Size	Part No.	Type
[mm]		
5	548 011	DYSC-5-5-Y1F
7	548 012	DYSC-7-5-Y1F
8	548 013	DYSC-8-8-Y1F
12	548 014	DYSC-12-12-Y1F

Shock absorbers YSRW

Peripherals overview and type codes

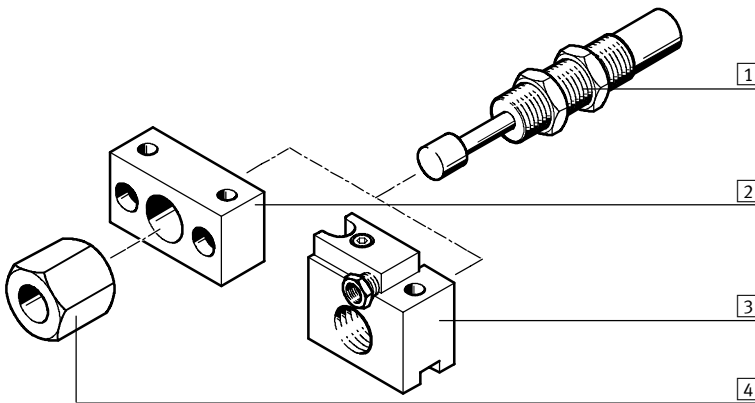

Accessories			
	Type	Brief description	→ Page/Internet
1	Shock absorber YSRW	Hydraulic shock absorber with progressive cushioning characteristic	21
2	Mounting flange YSRF	Mounting option for shock absorber	36
3	Mounting flange YSRF-S	Mounting option for shock absorber with attached stop sleeve and position sensing	37
4	Stop limiters YSRA	Stroke limiter for shock absorber	38

	YSRW	10	20
Type			
YSRW	Shock absorber		
Size			
Stroke [mm]			

Shock absorbers YSRW

Technical data

Function

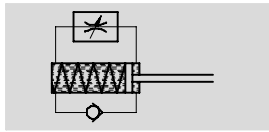

- \varnothing - Size
5 ... 20 mm
- | - Stroke length
8 ... 34 mm



General technical data							
Size	5	7	8	10	12	16	20
Stroke [mm]	8	10	14	17	20	26	34
Mode of operation	Hydraulic shock absorbers with return spring Single acting, pushing						
Cushioning	Self-adjustable						
Cushioning length [mm]	8	10	14	17	20	26	34
Type of mounting	With locknut						
Impact velocity [m/s]	0.1 ... 2		0.1 ... 3				
Mounting position	Any						
Product weight [g]	8	18	34	54	78	190	330
Ambient temperature [°C]	-10 ... +80						
Corrosion resistance class CRC ¹⁾	2						

- 1) Corrosion resistance class 2 to Festo standard 940 070
Components subject to moderate corrosion stress. Externally visible parts with primarily decorative surface requirements which are in direct contact with a normal industrial environment or media such as coolants or lubricating agents

Reset time [s]							
Size	5	7	8	10	12	16	20
Reset time ¹⁾	≤ 0.2				≤ 0.3		

- 1) The specified technical data refers to ambient temperature. At higher temperatures in the 80 °C range, the max. mass and the cushioning work must be reduced by 50% approx. At -10 °C, the reset time may be up to 1 second

Forces [N]							
Size	5	7	8	10	12	16	20
Min. insertion force ¹⁾	7.5	10	18	25	35	60	100
Max. stop force ²⁾ in end positions	200	300	500	700	1,000	2,000	3,000
Min. resetting force ³⁾	0.9	1.2	2.5	3.5	5	6	10

- 1) This is the minimum force that must be applied so that the shock absorber is pushed exactly into the retracted end position. This value is reduced correspondingly in the event of an extended external end-position
2) If the max. stop force is exceeded, a fixed stop (e.g. YSRA) 0.5 mm must be fitted before the end of stroke
3) This is the maximum force which may act upon the piston rod, allowing for full extension of the shock absorber (e.g. protruding stem)

Energies [J]							
Size	5	7	8	10	12	16	20
Max. energy absorption per stroke	1.3	2.5	4	8	12	35	70
Max. energy absorption per hour	10,000	15,000	21,000	30,000	41,000	68,000	100,000
Max. residual energy	0.01		0.02	0.03	0.05	0.16	0.32

Mass range [kg]							
Size	5	7	8	10	12	16	20
Permissible mass range up to	2	5	10	20	30	50	80

Shock absorbers YSRW

Technical data

FESTO

Materials							
Size	5	7	8	10	12	16	20
Housing	Brass, nickel-plated			Galvanised steel			
Piston rod	High-alloy steel						
Buffer	Polyamide						
Seals	Nitrile rubber						
Note on materials	Free of copper, PTFE and silicone						
	Conforms to RoHS						

Selection graph for self-adjusting shock absorbers with progressive characteristics YSRW

Impact velocity dependent on mass m

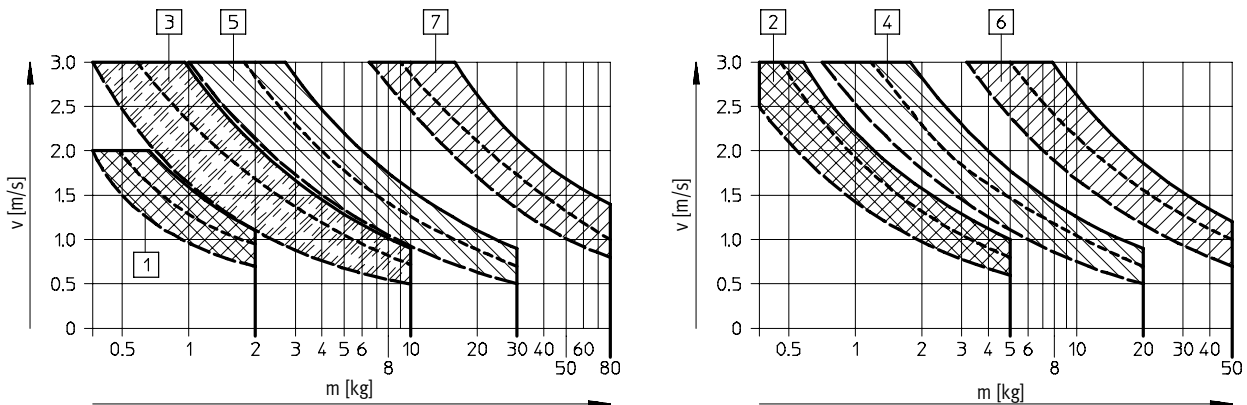

Three force curves are shown for each shock absorber. Interim values must be calculated by averaging.

- 1 YSRW-5-8
- 2 YSRW-7-10
- 3 YSRW-8-14
- 4 YSRW-10-17
- 5 YSRW-12-20
- 6 YSRW-16-26
- 7 YSRW-20-34

Shock absorber	Max. stop force in end position	Force A = <u> </u>	Force A = <u> </u>	Force A = <u> </u>
YSRW-5-8	200 N	0 N	50 N	100 N
YSRW-7-10	300 N	0 N	75 N	150 N
YSRW-8-14	500 N	0 N	100 N	200 N
YSRW-10-17	700 N	0 N	150 N	300 N
YSRW-12-20	1,000 N	0 N	200 N	400 N
YSRW-16-26	2,000 N	0 N	500 N	800 N
YSRW-20-34	3,000 N	0 N	800 N	1,200 N

Shock absorbers YSRW

Technical data

FESTO

Dimensions

Download CAD data → www.festo.com

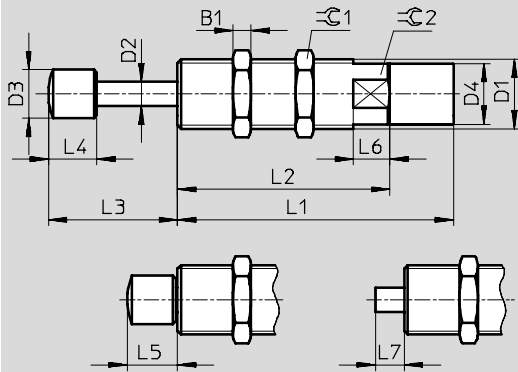

Size	B1	D1	D2 ∅	D3 ∅	D4 ∅	L1	L2	L3
[mm]						±0.1	±0.3	
5	3	M8x1	2.5	5 ±0.1	6.7 ±0.05	33.5	22.5	13.8 +0.6/-0.25
7	3.5	M10x1	3	6 ±0.1	8.6 ±0.05	41	30	17.3 +0.7/-0.25
8	4	M12x1	4	8 ±0.2	10.4 ±0.1	53	40	22.3 +0.7/-0.25
10	5	M14x1	5	10 ±0.2	12.4 ±0.1	62	49	27.5 +0.7/-0.25
12	5	M16x1	6	12 ±0.2	14.5 ±0.1	72.5	59.5	32.5 +0.7/-0.25
16	6	M22x1.5	8	16 ±0.2	20 ±0.1	91	70	42.5 +0.7/-0.35
20	8	M26x1.5	10	20 ±0.2	24 ±0.1	112	91	54.5 +0.7/-0.35

Size	L4	L5	L6	L7	⊖C1	⊖C2	Max. tightening torque ⊖C1
[mm]			+0.5				[Nm]
5	5.5 ±0.1	5.8 +0.35/-0.25	5	3.5 ±0.25	10	7	2
7	7 ±0.2	7.3 +0.35/-0.25	6	4.3 ±0.25	13	9	3
8	8 ±0.2	8.3 +0.4/-0.25	8	5.3 +0.3/-0.25	15	11	5
10	10 ±0.2	10.5 +0.4/-0.25	10	6.5 +0.3/-0.25	17	13	8
12	12 ±0.2	12.5 +0.4/-0.25	12	7.5 +0.3/-0.25	19	15	20
16	16 ±0.2	16.5 +0.4/-0.25	12	9.5 +0.3/-0.25	27	20	35
20	20 ±0.2	20.5 +0.4/-0.25	12	11.5 +0.3/-0.25	32	24	60

Ordering data

Size	Part No.	Type
[mm]		
5	191 192	YSRW-5-8
7	191 193	YSRW-7-10
8	191 194	YSRW-8-14
10	191 195	YSRW-10-17
12	191 196	YSRW-12-20
16	191 197	YSRW-16-26
20	191 198	YSRW-20-34

Shock absorbers DYSW

Type codes

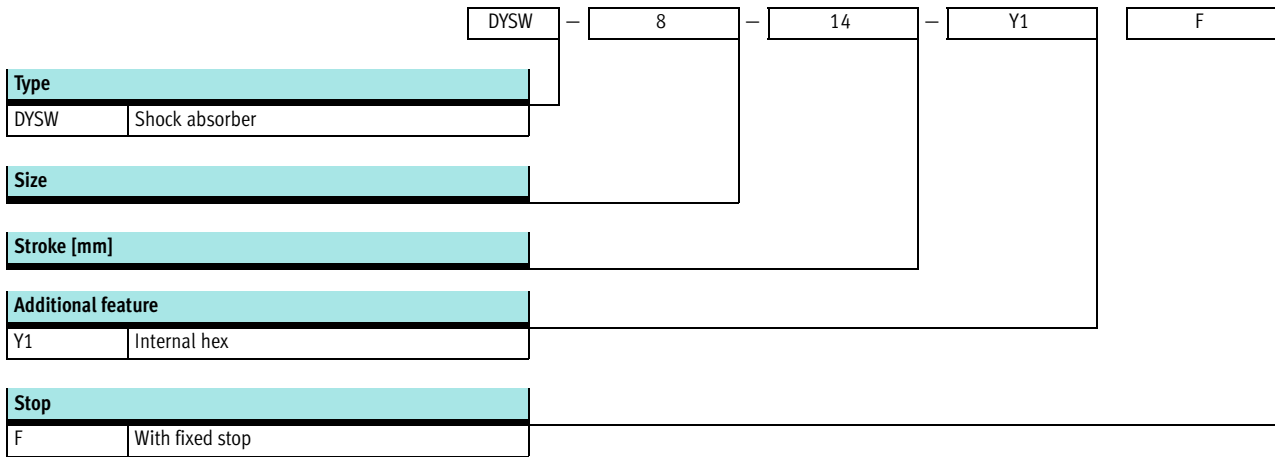



Shock absorbers DYSW

Technical data

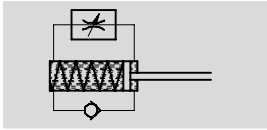
Function



-  Size
4 ... 12
-  Stroke length
6 ... 20 mm



General technical data						
Size	4	5	7	8	10	12
Stroke [mm]	6	8	10	14	17	20
Mode of operation	Hydraulic shock absorber with spring return Single acting, pushing					
Cushioning	Self-adjusting, soft characteristic curve					
Cushioning length [mm]	6	8	10	14	17	20
Type of mounting	With lock nut					
Impact velocity [m/s]	0.1 ... 2		0.1 ... 3			
Assembly position	Any					
Product weight [g]	6	11	21	42	67	91
Ambient temperature [°C]	-10 ... +80					

Reset time [s]						
Size	4	5	7	8	10	12
Reset time ¹⁾	≤ 0.2					≤ 0.3

1) The specified technical data refers to ambient temperature. At higher temperatures in the 80 °C range, the max. mass and the cushioning work must be reduced by 50% approx. At -10 °C, the reset time may be up to 1 second

Forces [N]						
Size	4	5	7	8	10	12
Min. insertion force ¹⁾	6.5	7.5	10	18	25	35
Max. stop force ²⁾ in end positions (housing)	100	200	300	500	700	1,000
Min. resetting force ³⁾	0.7	0.9	1.2	2.5	3.5	5

- 1) This is the minimum force that must be applied so that the shock absorber is pushed exactly into the retracted end position. This value is reduced correspondingly in the event of an extended external end position
- 2) If the max. stop force is exceeded, a fixed stop (e.g. YSRA) 0.5 mm must be fitted before the end of stroke
- 3) This is the maximum force which may act upon the piston rod, allowing for full extension of the shock absorber (e.g. protruding stem)

Energies [J]						
Size	4	5	7	8	10	12
Max. energy absorption per stroke	0.8	1.3	2.5	4	8	12
Max. energy absorption per hour	7,000	10,000	15,000	21,000	30,000	41,000
Max. residual energy	0.006	0.01	0.01	0.02	0.03	0.05

Mass range [kg]						
Size	4	5	7	8	10	12
Mass range up to	1.2	2	5	10	20	30

Shock absorbers DYSW

Technical data

FESTO

Materials						
Size	4	5	7	8	10	12
Housing	Brass, nickel-plated					Galvanised steel
Piston rod	High-alloy steel					
Buffer	Polyamide					
Seals	Nitrile rubber					
Note on materials	Free of copper, PTFE and silicone					
	Conforms to RoHS					

Selection graph for self-adjusting shock absorbers with progressive characteristics DYSW

Impact velocity dependent on mass m

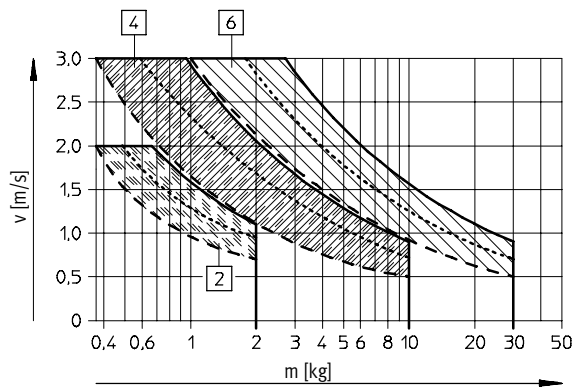
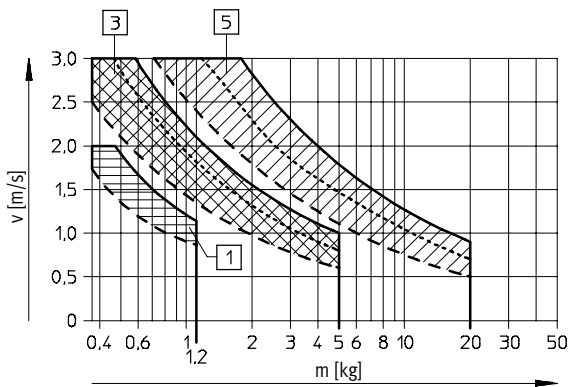

Three force curves are shown for each shock absorber. Interim values must be calculated by averaging.

- 1 DYSW-4-6-Y1F
- 2 DYSW-5-8-Y1F
- 3 DYSW-7-10-Y1F

- 4 DYSW-8-14-Y1F
- 5 DYSW-10-17-Y1F
- 6 DYSW-12-20-Y1F

Shock absorber	Max. stop force in end position (housing)	Force A =		
		—————	- - - - -	- - - - -
DYSW-4-6-Y1F	100	0 N	-	50 N
DYSW-5-8-Y1F	200	0 N	50 N	100 N
DYSW-7-10-Y1F	300	0 N	75 N	150 N
DYSW-8-14-Y1F	500	0 N	100 N	200 N
DYSW-10-17-Y1F	700	0 N	150 N	300 N
DYSW-12-20-Y1F	1,000	0 N	200 N	400 N

Shock absorbers DYSW

Technical data

FESTO

Dimensions

Download CAD data → www.festo.com

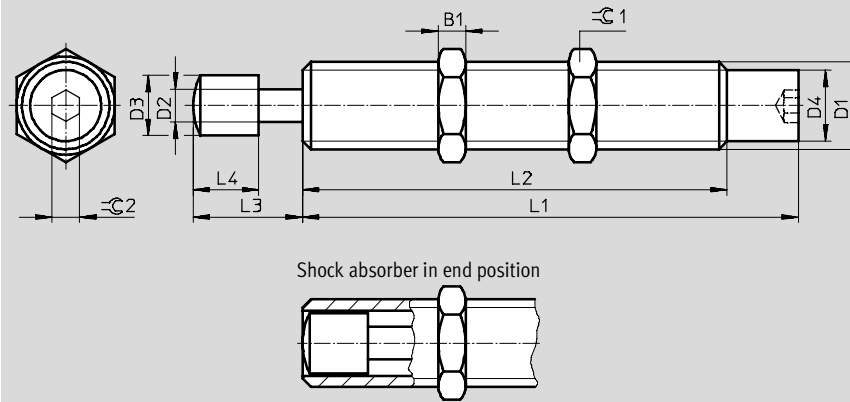

Size	B1	D1	D2 Ø	D3 Ø	D4 Ø	L1
[mm]						+0.1
4	2.5	M6x0.5	2	3.5±0.05	5.35±0.05	35.5
5	3	M8x1	2.5	4.7±0.05	6.7±0.05	43.1
7	3.5	M10x1	3	6±0.1	8.6±0.05	52.05
8	4	M12x1	4	7±0.1	10.4±0.1	66.05
10	5	M14x1	5	9±0.1	12.4±0.1	77.55
12	5	M16x1	6	11±0.1	14.4±0.1	90.75

Size	L2 +0.3 -0.2	L3	L4	≡C1	≡C2	Max. tightening torque ≡C1 [Nm]
[mm]						
4	25.5	6+0.30/-0.24	4±0.05	8	2	1
5	33.1	8+0.32/-0.28	5.5±0.1	10	2.5	2
7	41.05	10+0.37/-0.28	7±0.2	13	3	3
8	53.05	14+0.37/-0.28	8±0.2	15	4	5
10	64.55	17+0.37/-0.28	10±0.2	17	4	8
12	77.75	20+0.45/-0.30	12±0.2	19	5	20

Ordering data

Size [mm]	Part No.	Type
4	548 070	DYSW-4-6-Y1F
5	548 071	DYSW-5-8-Y1F
7	548 072	DYSW-7-10-Y1F
8	548 073	DYSW-8-14-Y1F
10	548 074	DYSW-10-17-Y1F
12	548 075	DYSW-12-20-Y1F

Stop elements YSRWJ

Peripherals overview and type codes

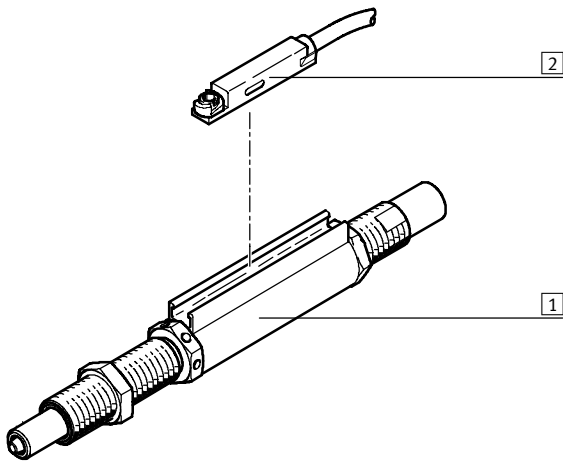

Accessories			
	Type	Brief description	→ Page/Internet
1	Stop element YSRWJ	Hydraulic shock absorber with progressive cushioning characteristic. The cushioning length is adjustable	29
2	Proximity switches SME-/SMT-8	Sensing option for end positions	39

		YSRWJ	-	7	-	10	-	A
Type								
YSRWJ	Shock absorber							
Size								
Stroke [mm]								
Position sensing								
A	Position sensing							



Stop elements YSRWJ

Technical data

FESTO

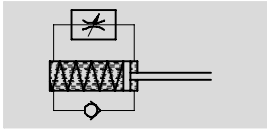
Function



-  Size
5 ... 8 mm
-  Stroke length
7.5 ... 13.5 mm



General technical data			
Size	5	7	8
Stroke [mm]	8	10	14
Mode of operation	A piston rod in front of the shock absorber transmits the force to the shock absorber. This serves as the end stop and actuates the proximity sensor via a magnet mounted on it		
	Single acting, pushing		
Cushioning	Self-adjustable		
Cushioning length [mm]	8	10	14
Type of mounting	With locknut		
Position sensing	Via proximity sensor		
Impact velocity [m/s]	0.05 ... 2	0.05 ... 3	
Repetition accuracy [mm]	0.02		
Mounting position	Any		
Product weight [g]	45	75	110
Ambient temperature [°C]	0 ... +60		
Corrosion resistance class CRC ¹⁾	2		

- 1) Corrosion resistance class 2 to Festo standard 940 070
Components subject to moderate corrosion stress. Externally visible parts with primarily decorative surface requirements which are in direct contact with a normal industrial environment or media such as coolants or lubricating agents

Reset time [s]			
Size	5	7	8
Reset time ¹⁾	≤ 0.2		

- 1) The specified technical data refers to ambient temperature. At higher temperatures in the 80 °C range, the max. mass and the cushioning work must be reduced by 50% approx. At -10 °C, the reset time may be up to 1 second

Forces [N]			
Size	5	7	8
Min. insertion force ¹⁾	5	18	80
Max. stop force ²⁾ in end positions	200	300	500
Min. resetting force ³⁾	1.5	2	3.5

- 1) This is the minimum force that must be applied so that the shock absorber is pushed exactly into the retracted end position
2) Impact force may not exceed the maximum specified value
3) This is maximum force that can be exerted on the piston rod so that the shock absorber advances fully

Energies [J]			
Size	5	7	8
Max. energy absorption per stroke	1	2	3
Max. energy absorption per hour	10,000	15,000	21,000
Max. residual energy	0.01	0.02	

Mass range [kg]			
Size	5	7	8
Permissible mass range up to	2	5	10

Stop elements YSRWJ

Technical data

FESTO

Materials

Sectional view

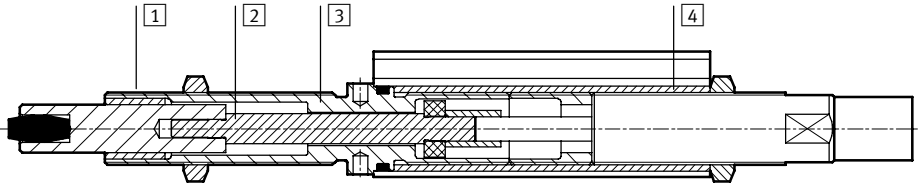

Stop element

1	Housing	Brass, nickel-plated
2	Stop bolt	Steel, stainless and reinforced
3	Distance sleeve	Aluminium
4	Threaded barrel	Brass, nickel-plated
-	Note on materials	Free of copper, PTFE and silicone Conforms to RoHS

Selection graphs for limit stops with shock absorber YSRWJ

Impact velocity dependent on mass m

YSRWJ-5-8-A

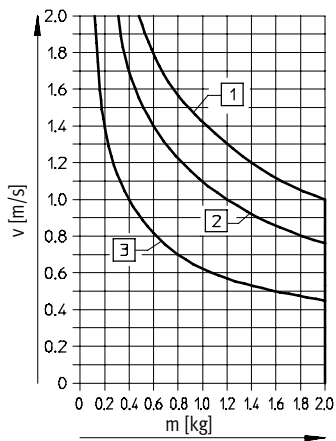

- 1 Without additional force
- 2 With additional force A = 50 N
- 3 With additional force A = 100 N

YSRWJ-7-10-A

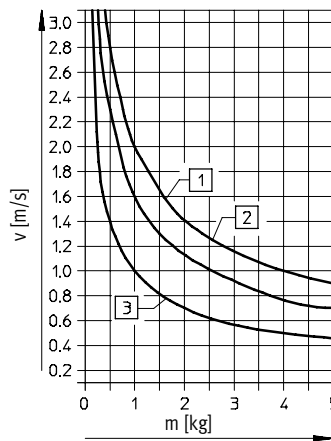

- 1 Without additional force
- 2 With additional force A = 75 N
- 3 With additional force A = 150 N

YSRWJ-8-14-A

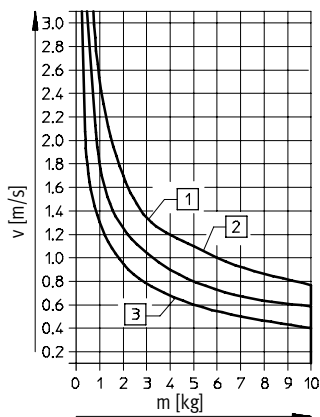

- 1 Without additional force
- 2 With additional force A = 100 N
- 3 With additional force A = 150 N

Stop elements YSRWJ

Technical data

FESTO

Mode of operation

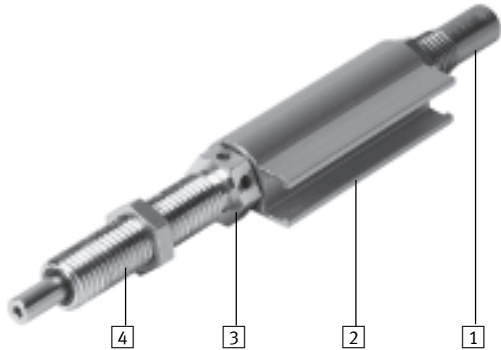

- 1 Soft cushioning characteristics – cushioning stroke is adjustable
- 2 End-position sensing via proximity sensor SME-/SMT-8 that can be integrated
- 3 Precision end-position adjustment
- 4 Precision end position thanks to internal, metallic inserts

Dimensions

Download CAD data → www.festo.com

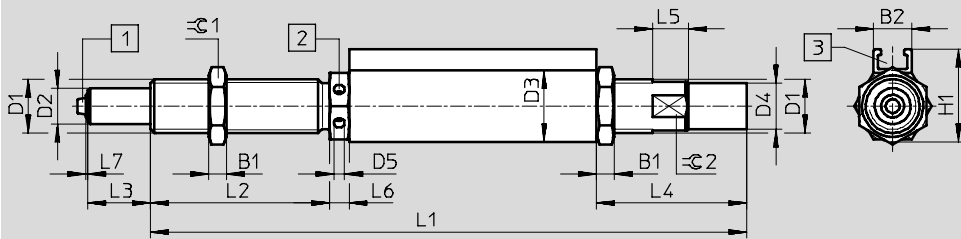

- 1 Rubber buffer, only with sizes: YSRWJ-7-10-A and YSRWJ-8-14-A
- 2 Precision end-position adjustment
- 3 Slot for proximity sensor SME-/SMT-8

Size	B1	B2	D1	D2	D3	D4	D5	H1	L1
[mm]		+0.4			+0.1		+0.1	+0.3	+0.3/-0.1
5	3	8.1	M8x1	4	12	6.7 ±0.05	2	16.5	97.4
7	3.5	8.5	M10x1	6	14	8.6 ±0.05	2.4	18.3	144.8
8	4	8.5	M12x1	8	16	10.4 ±0.1	2.4	20.75	133.3

Size	L2	L3	L4	L5	L6	L7	⌀C1	⌀C2	Max. tightening torque ⌀C1 [Nm]
[mm]	+0.4		+0.45/-0.1	+0.5	+0.1/-0.55	+0.3			
5	32.5	8 +0.7/-0.55	21.6	5	4.4	0.5	10	7	2
7	40	10 +0.8/-0.55	21.1	6	4	0.5	13	9	3
8	40	14 +0.8/-0.55	33.6	8	4.4	0.5	15	11	5

Ordering data

Size [mm]	Part No.	Type
5	192 968	YSRWJ-5-8-A
7	192 967	YSRWJ-7-10-A
8	192 966	YSRWJ-8-14-A

Hydraulic cushioning cylinders YDR

Peripherals overview and type codes

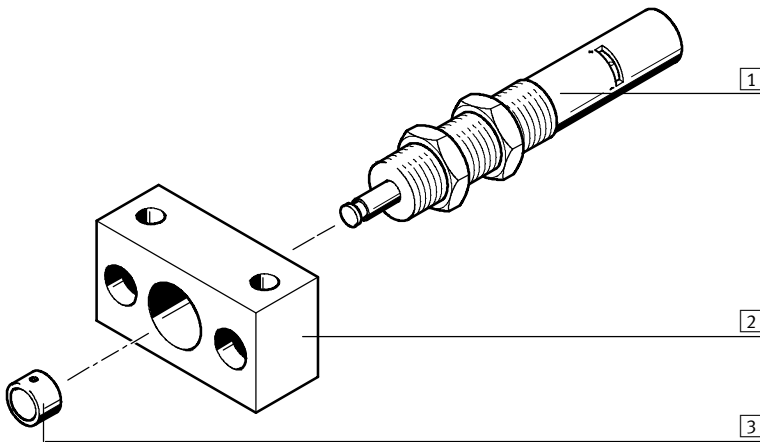

Accessories			
	Type	Brief description	→ Page/Internet
1	Hydraulic cushioning cylinder YDR	Hydraulic cushioning cylinder with reset spring for slow feed speeds	33
2	Mounting flange YSRF	Mounting option for shock absorber	36
3	Buffer YSRP	For the protection of piston rod	38
-	Oil gun YSR-OEP	For topping up oil	38
-	Special oil OFSB-1	Replacement oil	38

	YDR	-	16	-	20
Type					
YDR	Hydraulic cushioning cylinder				
Size					
Stroke [mm]					

Hydraulic cushioning cylinders YDR

Technical data

Function

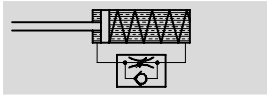

- \varnothing - Size
16 ... 32 mm
- | - Stroke length
20 ... 60 mm



General technical data				
Size	16	20	25	32
Stroke [mm]	20	25	40	60
Mode of operation	Hydraulic cushioning cylinder with return spring			
Cushioning	Adjustable			
Type of mounting	With locknut			
Impact velocity, max. [m/s]	0.3		0.4	
Feed speed [mm/s]	0.2 ... 100			
Product weight [g]	280	460	900	1,600
Ambient temperature [°C]	0 ... +80			

Reset times [s]				
Size	16	20	25	32
Short ¹⁾	≤ 0.4			
Long ²⁾	≤ 1			

- 1) Piston rod retracted for short period ≤ 30 s
- 2) Piston rod retracted for longer period ≤ 6 h

Forces [N]				
Size	16	20	25	32
Min. feed force	60	70	90	120
Max. feed force ¹⁾	1,600	2,500	4,000	6,400
Resetting force	25	25	35	35

- 1) Corresponds to max. force in the end position

Energies [J]				
Size	16	20	25	32
Max. energy absorption per stroke	32	62.5	160	384
Max. energy absorption per hour	65,000	90,000	150,000	220,000
Max. residual energy	0.16	0.32	0.8	2

Hydraulic cushioning cylinders YDR

Technical data

FESTO

Materials

Sectional view

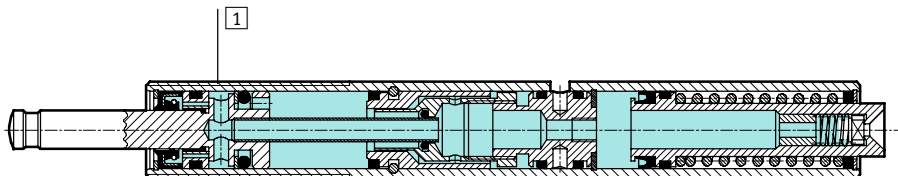

Hydraulic cushioning cylinder

1	Housing	Galvanised steel
-	Seals	Nitrile rubber, polyurethane
-	Note on materials	Conforms to RoHS

Feed speed v dependent on feed force F (cushioning characteristic)

YDR-16-20

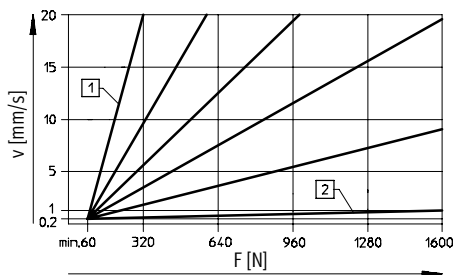

YDR-20-25

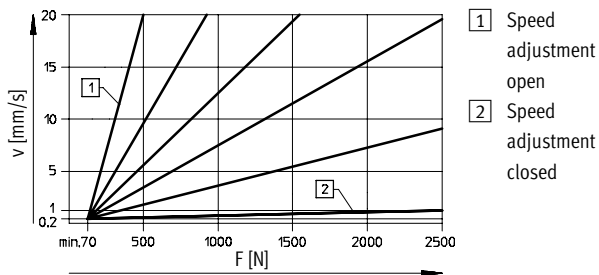

YDR-25-40

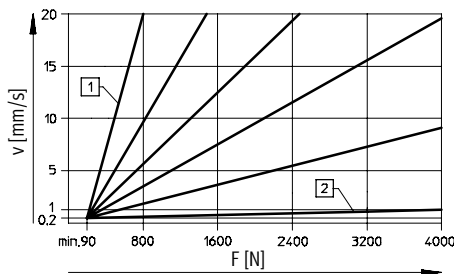

YDR-32-60

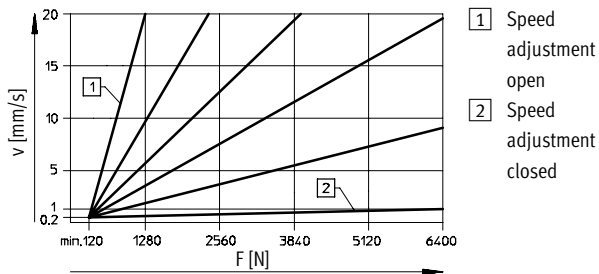

Hydraulic cushioning cylinders YDR

Technical data

FESTO

Dimensions

Download CAD data → www.festo.com

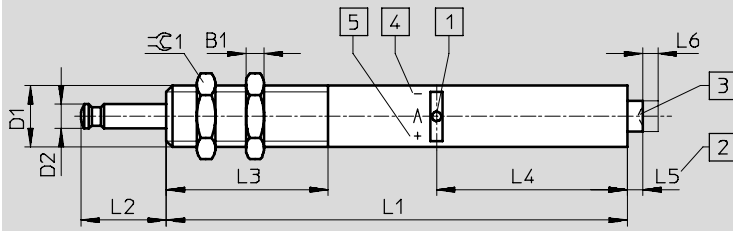

- 1 Speed control
- 2 Oil reservoir
- 3 Oil top-up
(after 0.6 million load cycles)
- 4 - = slower speed
- 5 + = faster speed

Size	B1	D1	D2	L1	L2	L3
[mm]						
16	6	M20x1.25	8	151	28	53
20	8	M24x1.25	10	174	35	60
25	10	M30x1.5	12	227	52	80
32	12	M37x1.5	15	275	75	108

Size	L4	L5 max.	L6	⊖C1	Max. tightening torque ⊖C1
[mm]					[Nm]
16	62.5	5	5	24	35
20	72.5	6	6	30	60
25	89.8	9	10	36	80
32	106.3	13	15	46	100

Ordering data

Size	Part No.	Type
[mm]		
16	14 900	YDR-16-20
20	14 901	YDR-20-25
25	14 902	YDR-25-40
32	14 903	YDR-32-60

Accessories for cushioning components

Technical data

Mounting flange YSRF/YSRF-C

Material:
Steel

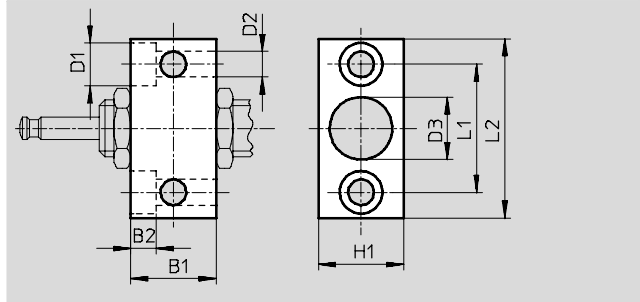
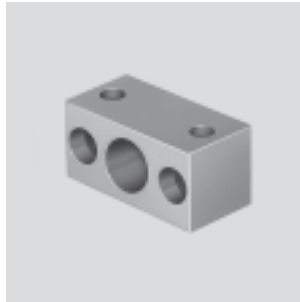

Possible combinations				
Cushioning components	YSR	YSR-C	YSRW	YDR
Mounting flange				
YSRF				
YSRF-8	-	■ ¹⁾	■ ¹⁾	-
YSRF-12	■	-	-	-
YSRF-16	■	-	-	■
YSRF-20	■	-	-	■
YSRF-25	■	■	-	■
YSRF-32	■	■	-	■
YSRF-C				
YSRF-8-C	■	■	■	-
YSRF-12-C	-	■	■	-
YSRF-16-C	-	■	■	-
YSRF-20-C	-	■	■	-

1) For shock absorber size Ø 7

Dimensions and ordering data												
YSRF												
For size [mm]	B1	B2	D1	D2	D3	H1	L1	L2	CRC ¹⁾	Weight [g]	Part No.	Type
8	16	5.5	10	5.5	10.2	16	25	38	2	50	11 681	YSRF-8
12	25	6.8	11	6.6	15.2	25	36	50	2	175	11 682	YSRF-12
16	30	9	15	9	20.2	30	45	63	2	300	11 683	YSRF-16
20	36	11	18	11	24.2	36	56	78	2	535	11 684	YSRF-20
25	45	13	20	13.5	30.2	45	63	86	2	895	11 685	YSRF-25
32	55	15	24	15.5	37.2	55	80	108	2	1,730	11 686	YSRF-32

1) Corrosion resistance class 2 according to Festo standard 940 070
Components requiring moderate corrosion resistance. Externally visible parts with primarily decorative surface requirements which are in direct contact with a surrounding industrial atmosphere or media such as cooling or lubricating agents

YSRF-C												
For size [mm]	B1	B2	D1	D2	D3	H1	L1	L2	CRC ¹⁾	Weight [g]	Part No.	Type
8	20	5.5	10	5.5	12.2	20	28	41	2	90	34 575	YSRF-8-C
12	25	6.8	11	6.6	16.2	25	36	50	2	180	34 576	YSRF-12-C
16	32	9	15	9	22.2	32	45	63	2	330	34 577	YSRF-16-C
20	40	11	18	11	26.2	40	56	78	2	700	34 578	YSRF-20-C

1) Corrosion resistance class 2 according to Festo standard 940 070
Components requiring moderate corrosion resistance. Externally visible parts with primarily decorative surface requirements which are in direct contact with a surrounding industrial atmosphere or media such as cooling or lubricating agents

Accessories for cushioning components

Technical data

Mounting flange YSRF-S-C

Material:
Aluminium, steel
Free of copper, PTFE and silicone

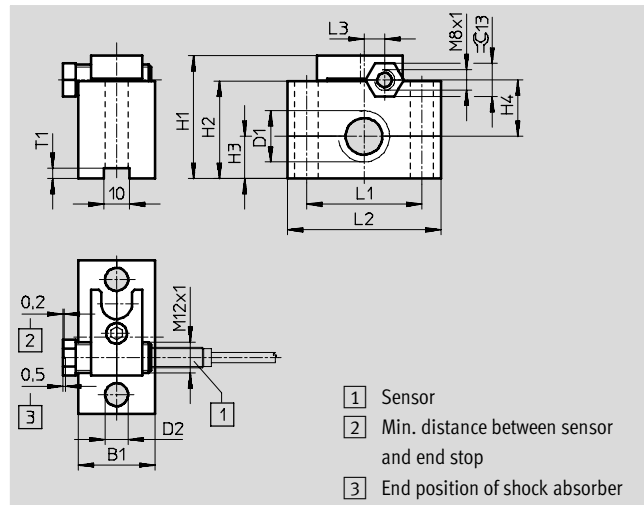

Possible combinations				
Cushioning components	YSR	YSR-C	YSRW	YDR
Mounting flange				
YSRF-S-8-C	-	■	■	-
YSRF-S-12-C	-	■	■	-
YSRF-S-16-C	-	■	■	-
YSRF-S-20-C	-	■	■	-

Dimensions and ordering data														
For size	B1	D1	D2 ∅	H1	H2	H3	H4	L1	L2	L3	T1	Weight [g]	Part No.	Type
8	20	M12x1	5.5	35	25	9.5	16	32	45	4	2	12	34 579	YSRF-S-8-C
12	25	M16x1	6.6	42	32	12.5	20	36	50	3	4	130	34 580	YSRF-S-12-C
16	30	M22x1.5	9	48	38	16.5	22	45	60	8	4	180	34 581	YSRF-S-16-C
20	30	M26x1.5	11	52	42	19	23.5	56	80	11.5	4	250	34 582	YSRF-S-20-C

- - Note
Inductive sensors for position sensing → 39

Accessories for cushioning components

Technical data

Buffer YSRP

Material:
Steel, polyurethane

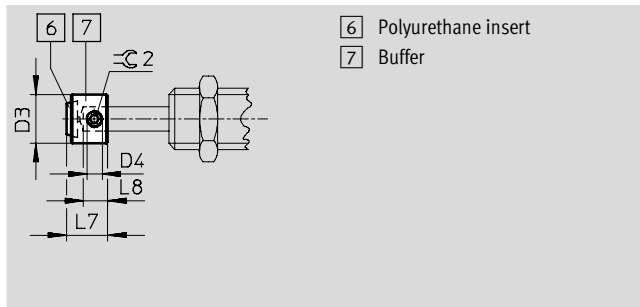

Dimensions and ordering data									
For size [mm]	D3	D4	L7	L8	± 0.2	CRC ¹⁾	Weight [g]	Part No.	Type
8	8	M2	6,7	4	0,9	2	4	539 638	YSRP-8
12	12	M4	10	6	2	2	7	11 133	YSRP-12
16	16	M5	13.5	8	2.5	2	15	11 134	YSRP-16
20	20	M6	17	10	3	2	27	11 135	YSRP-20
25	25	M8	20.5	12	4	2	52	11 136	YSRP-25
32	32	M8	26	15	4	2	110	11 137	YSRP-32

1) Corrosion resistance class 2 according to Festo standard 940 070
Components requiring moderate corrosion resistance. Externally visible parts with primarily decorative surface requirements which are in direct contact with a surrounding industrial atmosphere or media such as cooling or lubricating agents

Stop limiter YSRA-C

Material:
Steel

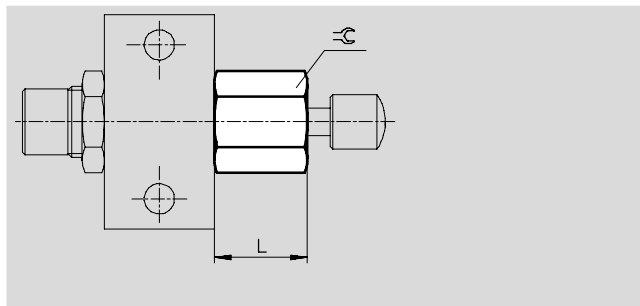

Dimensions and ordering data					
For size [mm]	L	± 0.2	Weight [g]	Part No.	Type
7	14.5	13	12	150 932	YSRA-7-C
8	18	15	28	150 933	YSRA-8-C
12	24.5	19	48	150 934	YSRA-12-C

Oil gun YSR-OEP



Special oil OFSB-1







Ordering data	
Part No.	Type
11 698	YSR-OEP

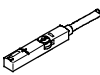

Ordering data	
Part No.	Type
207 873	OFSB-1

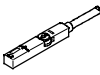

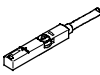
Accessories for cushioning components

Technical data

Ordering data – Proximity sensors for T-slot, magneto-resistive						Technical data → Internet: smt	
	Type of mounting	Switch output	Electrical connection	Cable length [m]	Part No.	Type	
N/O contact							
	Insertable in the slot from above, flush with cylinder profile	PNP	Cable, 3-wire	2.5	543 867	SMT-8M-PS-24V-K-2,5-OE	
			Plug M8x1, 3-pin	0.3	543 866	SMT-8M-PS-24V-K-0,3-M8D	
	Insertable in the slot lengthwise, flush with the cylinder profile	NPN	Cable, 3-wire	2.5	543 870	SMT-8M-NS-24V-K-2,5-OE	
			Plug M8x1, 3-pin	0.3	543 871	SMT-8M-NS-24V-K-0,3-M8D	
	Insertable in the slot lengthwise, flush with the cylinder profile	PNP	Cable, 3-wire	2.5	175 436	SMT-8-PS-K-LED-24-B	
			Plug M8x1, 3-pin	0.3	175 484	SMT-8-PS-S-LED-24-B	
N/C contact							
	Insertable in the slot from above, flush with cylinder profile	PNP	Cable, 3-wire	7.5	543 873	SMT-8M-PO-24V-K7,5-OE	

Ordering data – Proximity sensors for T-slot, magnetic reed						Technical data → Internet: sme	
	Type of mounting	Switch output	Electrical connection	Cable length [m]	Part No.	Type	
N/O contact							
	Insertable in the slot from above, flush with cylinder profile	Contacting	Cable, 3-wire	2.5	543 862	SME-8M-DS-24V-K-2,5-OE	
			Plug M8x1, 3-pin	0.3	543 861	SME-8M-DS-24V-K-0,3-M8D	
	Insertable in the slot lengthwise, flush with the cylinder profile	Contacting	Cable, 3-wire	2.5	150 855	SME-8-K-LED-24	
			Plug M8x1, 3-pin	0.3	150 857	SME-8-S-LED-24	
N/C contact							
	Insertable in the slot lengthwise, flush with the cylinder profile	Contacting	Cable, 3-wire	7.5	160 251	SME-8-0-K-LED-24	

Ordering data – Inductive sensors M8, for mounting flange YSRF-S-C						Technical data → Internet: sien	
	Electrical connection		Switch output	LED	Cable length [m]	Part No.	Type
	Cable	M8 plug					
NO contact							
	3 wires	–	PNP	■	2.5	150 386	SIEN-M8B-PS-K-L
	–	3-pin	PNP	■		150 387	SIEN-M8B-PS-S-L
NC contact							
	3 wires	–	PNP	■	2.5	150 390	SIEN-M8B-PO-K-L
	–	3-pin	PNP	■		150 391	SIEN-M8B-PO-S-L

Ordering data – Connecting cables					Technical data → Internet: nebu	
	Electrical connection, left	Electrical connection, right	Cable length [m]	Part No.	Type	
	Straight socket, M8x1, 3-pin	Cable, open end, 3-wire	2.5	541 333	NEBU-M8G3-K-2.5-LE3	
			5	541 334	NEBU-M8G3-K-5-LE3	
	Angled socket, M8x1, 3-pin	Cable, open end, 3-wire	2.5	541 338	NEBU-M8W3-K-2.5-LE3	
			5	541 341	NEBU-M8W3-K-5-LE3	

Calculation tool for cushioning components

Technical data

FESTO

This selection aid helps you find the right shock absorber for every application.

When you are choosing a shock absorber, we recommend that you proceed as follows:

- Determine the following values, effective at the time of impact:
 - Force (A)
 - Equivalent mass m_{equiv}
 - Impact velocity (v)
- Select a shock absorber from the graphs on the following pages.
- Check your selection on the basis of its maximum cushioning energy ($W_{max.}$)

 Note
 Sizing software
 Shock absorber selection
www.festo.com

When you are choosing a shock absorber for your application, ensure that the following values are not exceeded:

- Permissible energy load per stroke:
 - $W_{min.} = 25\%$
 - $W_{max.} = 100\%$
- Recommended energy load per stroke:
 - $W_{opt.} = 50\% \dots 100\%$
- Max. energy absorption per hour
- Max. residual energy
- Max. stop force in end position

The (angular) velocity required in the formulae is the velocity at the time of the impact on the shock absorber. This depends on the dynamic characteristics of the drive component and is thus difficult to determine.

It is better to determine the mean velocity ($v_m = s/t$ or $\omega_m = \varphi/t$).

In order to prevent damage to the drive concerned, calculations should in the interests of safety be based on the following values:

- $v = 1.25 \dots 2 v_m$
- $\omega = 1.25 \dots 2 \omega_m$
- Guide values for linear motions:
 - Factor 2 with strokes < 50 mm,
 - factor 1.5 with strokes > 50 mm and < 100 mm,
 - factor 1.25 with strokes > 100 mm.

The fact that the (angular) velocity appears in the calculation as a squared value means that the expected error becomes considerably larger. The calculation can thus be regarded only as an approximation. The safety factor does, however, ensure that the selected shock absorber is not too small.

The following formulae are required for the calculation:

$$A = F + G$$

$$A = F + m \times g \times \sin \alpha$$

$$W_{total} = \frac{1}{2} \times m \times v^2 + A \times s < W_{max.}$$

$$W_h = W_{total} \times \text{Stroke} \div \text{Hours} < W_{hmax.}$$

The following applies additionally for rotary motions:

$$m_{equiv.} = \frac{J}{R^2}$$

$$v = \omega \times R$$

$$A = \frac{M}{R} + m \times g \times \sin \alpha \times \frac{a}{R}$$

The following abbreviations are used:

- | | | |
|--|---|---|
| <p>A = Additional force = F + G [N]</p> <p>F = Cylinder force minus frictional force [N]</p> <p>G = Force due to weight = $m \times g \times \sin \alpha$</p> <p>Special cases:</p> <p>$\alpha = 0^\circ$: Horizontal motion
G = 0</p> <p>$\alpha = 90^\circ$: Downward motion
G = $m \times g$</p> <p>$\alpha = 90^\circ$: Upward motion:
G = $-m \times g$</p> | <p>v = Impact velocity [m/s]</p> <p>$m_{equiv.}$ = Equivalent mass [kg]</p> <p>g = Acceleration due to gravity 9.81 [m/s²]</p> <p>s = Shock absorber stroke [m]</p> <p>α = Impact angle [°]</p> <p>W_{total} = Cushioning work/stroke [J]</p> <p>W_h = Cushioning work/hour [J]</p> | <p>J = Mass moment of inertia [kg x m²]</p> <p>R = Distance between mass pivot point and shock absorber [m]</p> <p>ω = Angular velocity [rad/s]</p> <p>M = Drive torque [Nm]</p> <p>a = Distance between centre of gravity of mass and pivot point</p> |
|--|---|---|

Calculation tool for cushioning components

Technical data

FESTO

Sizing example for linear motion

This example illustrates the procedure for the selection of a shock absorber for the application shown in the adjacent drawing:

$$A = F + m \times g \times \sin \alpha$$

$$= 190 \text{ N} + 50 \times 9.81 \times \sin \alpha \text{ N}$$

$$= 537 \text{ N}$$

$$m_{\text{equiv}} = m = 50 \text{ kg}$$

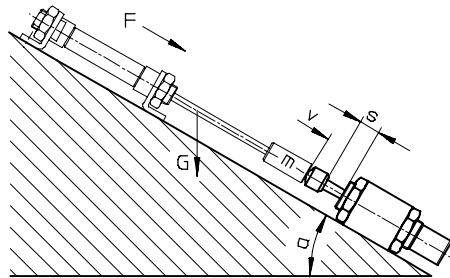

$$m = 50 \text{ kg}$$

$$v = 1.5 \text{ m/s}$$

$$\alpha = 45^\circ$$

$$F = 190 \text{ N}$$

(\varnothing 20 mm with p = 6 bar,
1,800 strokes per hour)

In the process of selecting shock absorbers on the basis of the graphs (see data sheets), the force (A) is governed by the first curve to the right of the point of intersection of the equivalent mass (m_{equiv}) and the impact velocity (v). The curves move to the left as the additional force increases.

Three force curves are given for each shock absorber. Interim values must be calculated by averaging. As the

graphs show (continuous line), possible choices are the shock absorbers YSR-25-40 and YSR-25-40-C. We must now determine whether the maximum permissible values for cushioning work (W_{max}) and cushioning work per hour (W_{hmax}) are not being exceeded. These maximum permissible values and the stroke length (s) can be found in the tables (below the graphs).

Experiment:

$$W_{\text{total}} = \frac{1}{2} \times m \times v^2 + A \times s$$

$$= (1/2 \times 50 \times 1.5^2 + 537 \times 0.04) \text{ Nm} = 78 \text{ J}$$

$$W_{\text{h}} = W_{\text{total}} \times \text{strokes/h}$$

$$= 78 \text{ Nm} \times 1,800$$

$$= 140,000 \text{ J}$$

For the above application, both shock absorbers are suitable.

Further selection criteria are adjustment facilities and size.

Result		
	YSR-25-40	YSR-25-40-C
W_{total}	78 J	78 J
W_{h}	140,000 J	140,000 J
$W_{\text{max.}}^{1)}$	160 J > W_{total}	160 J > W_{total}
$W_{\text{hmax.}}$	290,000 > $W_{\text{max.}}$	150,000 > $W_{\text{max.}}$

1) The degree of utilisation is 49% in both cases.

Calculation tool for cushioning components

Technical data

FESTO

Sizing example for rotary motion

Example for rotary motion:

$$m_{\text{equiv}} = J/R^2 = 8 \text{ kg}$$

$$v = \omega \times R$$

$$A = M/R = 40 \text{ N}$$

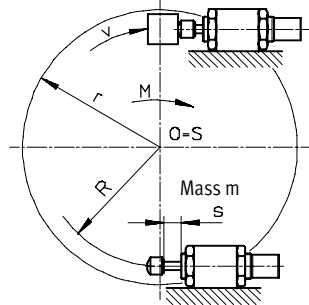

$$J = 2 \text{ kg m}^2$$

$$\omega = 4 \text{ rad/s}$$

$$R = 0.5 \text{ m}$$

$$M = 20 \text{ Nm}$$

900 strokes per hour

In the process of selecting shock absorbers on the basis of graphs (see data sheets), the force (A) is governed by the first curve to the right of the point of intersection of the equivalent mass (m_{equiv}) and the impact velocity (v). The curves move to the left as the additional force increases.

Three force curves are given for each shock absorber. Interim values must be calculated by averaging. As the graphs show (dotted line), possible

choices are the shock absorbers YSR-16-20 and YSR-16-20-C. We must now determine whether the maximum permissible values for cushioning work (W_{max}) and cushioning work per hour (W_{hmax}) are not being exceeded. These maximum permissible values and the stroke length (s) can be found in the tables (below the graphs).

Experiment:

$$\begin{aligned} W_{\text{total}} &= \frac{1}{2} \times m \times v^2 + A \times s \\ &= \left(\frac{1}{2} \times 8 \times 2^2 + 40 \times 0.02 \right) \text{ J} = 17 \text{ J} \end{aligned}$$

$$\begin{aligned} W_{\text{h}} &= W_{\text{total}} \times \text{strokes/h} \\ &= 17 \text{ J} \times 900 \\ &= 15,300 \text{ J} \end{aligned}$$

For the above application, both shock absorbers are suitable.

Further selection criteria are adjustment facilities and size.

Result		
	YSR-16-20	YSR-16-20-C
W_{total}	17 J	17 J
W_{h}	15,300 J	15,300 J
W_{max}	32 J > $W_{\text{total}}^{(1)}$	30 J > $W_{\text{total}}^{(2)}$
W_{hmax}	130,000 > W_{max}	64,000 > W_{max}

1) The degree of utilisation is 53%.

2) The degree of utilisation is 57%.