

sensori per cilindri

magnetic sensors for cylinders



Schema di collegamento: 2 fili

Wiring diagram: 2 wires

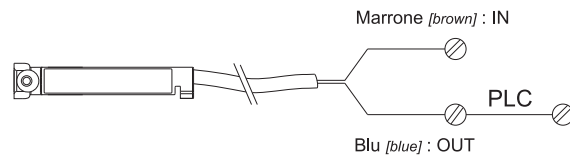

Modello Model	RS1-A	RS2-A	RS5-C	RS3-A	RS4-A
Funzione Function	Reed NA Reed NO 	Reed NA Reed NO 	Reed NC Reed NC 	Reed NA Reed NO 	Reed NA Reed NO
Numero fili Number of wires	2	2	2	2	2
Lunghezza fili Length of wires	standard: 2 m (5 m: RS1-A 5MT)	30 cm	2 m	2 m	30 cm
Connettore Connector	-	M8	-	-	M12
Tensione di esercizio Working tension	5-130V AC-DC	5-50V AC-DC	5-130V AC-DC	5-230V AC-DC	5-230V AC-DC
Corrente massima Max. current	200 mA	200 mA	200 mA	200 mA	200 mA
Potenza massima Max. power	6 W	6 W	6 W	10 W	10 W
Caduta di tensione Tension drop	3 V	3 V	-	3 V	3 V
Segnalazione stato uscita ON Output display ON	LED giallo yellow LED	LED giallo yellow LED	LED giallo yellow LED	LED giallo yellow LED	LED giallo yellow LED
Tempo di commutazione ON IN time	0.3 ms max				
Tempo di commutazione OFF OUT time	0.1 ms max				
Frequenza massima di commutazione Max. commutation frequency	400 Hz				
Resistenza di isolamento Insulation resistance	> 100 MΩ				
Resistenza alle vibrazioni Resistance to vibrations	2 kHz				
Vita elettrica: cicli Electric life: cycles	10 ⁷				
Temperatura di esercizio Temperature range	max +60°C				
Cavo tipo CEI 2022 II OR Cable type CEI 2022 II OR	2 x 0.14				
Grado di protezione Protection degree	IP 65				

6

sensori per cilindri

magnetic sensors for cylinders



Schema di collegamento: 3 fili

Wiring diagram: 3 wires

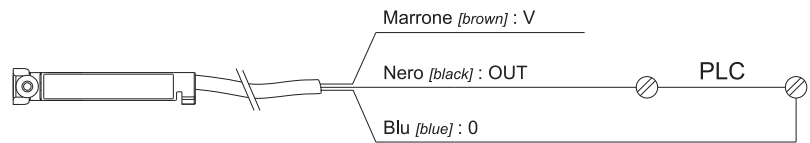

Modello Model	RS6-3F	RS7-3F	SH1-P	SH2-P
Funzione Function	Reed NA Reed NO 	Reed NA Reed NO 	Hall PNP Hall PNP 	Hall PNP Hall PNP
Numero fili Number of wires	3	3	3	3
Lunghezza fili Length of wires	2 m	30 cm	2 m	30 cm
Connettore Connector	-	M8	-	M8
Tensione di esercizio Working tension	5-30V AC-DC	5-30V AC-DC	5-30V DC	5-30V DC
Corrente massima Max. current	500 mA	500 mA	200 mA	200 mA
Potenza massima Max. power	6 W	6 W	4 W	4 W
Caduta di tensione Tension drop	0.1 V	0.1 V	0.7 V max	0.7 V max
Segnalazione stato uscita ON Output display ON	LED giallo yellow LED	LED giallo yellow LED	LED giallo yellow LED	LED giallo yellow LED
Tempo di commutazione ON IN time	0.3 ms max		0.8 ms max	
Tempo di commutazione OFF OUT time	0.1 ms max		0.3 ms max	
Frequenza massima di commutazione Max. commutation frequency	400 Hz		1 kHz	
Resistenza di isolamento Insulation resistance	> 100 MΩ		> 100 MΩ	
Resistenza alle vibrazioni Resistance to vibrations	2 kHz		2 kHz	
Vita elettrica: cicli Electric life: cycles	10 ⁷		10 ¹¹	
Temperatura di esercizio Temperature range	max +60°C		max +60°C	
Cavo tipo CEI 2022 II OR Cable type CEI 2022 II OR	3 x 0.14		3 x 0.14	
Grado di protezione Protection degree	IP 65		IP 65	

sensori per cilindri

magnetic sensors for cylinders



Dimensioni di ingombro

Overall dimensions

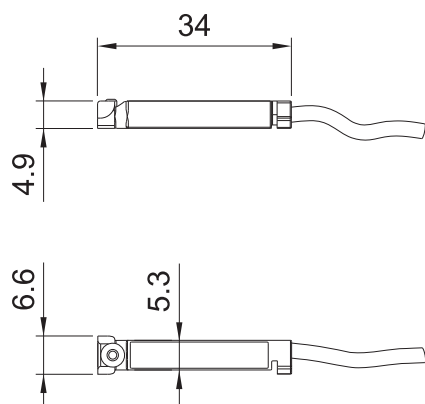

Dimensioni e schema connettore

Connector layout and dimensions

RS2-A

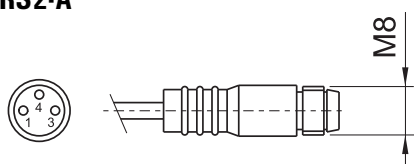

- 1 (marrone - brown) : IN
- 4 (nero - black) : OUT
- 3 (blu - blue) : non utilizzato [unused]



RS4-A

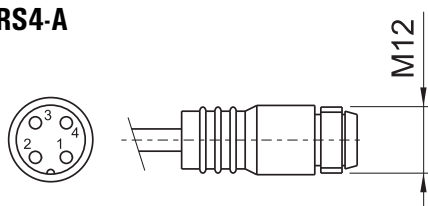

- 1 (marrone - brown) : IN
- 2 (bianco - white) : non utilizzato [unused]
- 3 (blu - blue) : non utilizzato [unused]
- 4 (nero - black) : OUT

RS7-3F SH2-P

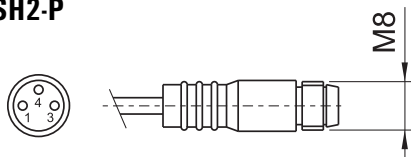

- 1 (marrone - brown) : V+
- 4 (nero - black) : OUT
- 3 (blu - blue) : V-

PROLUNGHE PER CAVO

Extensions for cable

	lunghezza length	codice di ordinazione order code
M8 3x0.25	3 m	26.164.0
	5 m	26.165.0
M12 3x0.34	3 m	26.166.0
	5 m	26.167.0

6

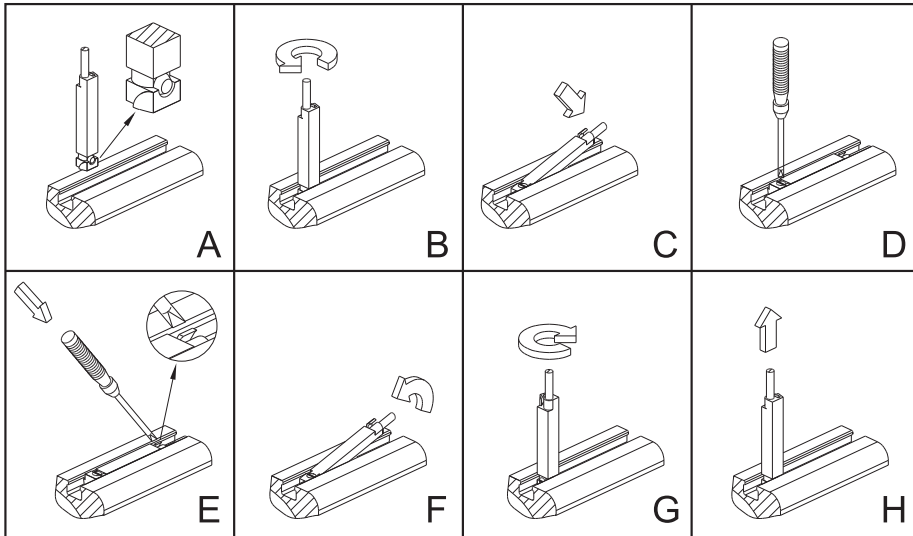

**MONTAGGIO DEI SENSORI SUI
CILINDRI ISO 6431**
mounting of sensor on cylinders ISO 6431

Istruzioni per l'installazione:

- A.** Inserire dall'alto il sensore come indicato in figura
- B.** Ruotare di 90° il corpo del sensore
- C.** Alloggiare il sensore nella cava tenendo in vista il taglio del grano
- D.** Individuare la posizione di lettura, quindi avvitare il grano

Istruzioni per la rimozione:

- E.** Una volta allentato il grano, agire sul dentino di blocco posteriore
- F.** Contemporaneamente sollevare il sensore aiutandosi con il cavo
- G.** Ruotare di 90° il corpo del sensore
- H.** Estrarre il sensore dalla cava

Instructions for installation:

- A.** Insert the sensor from above as indicated in the image
- B.** Rotate the body of the sensor by 90°
- C.** Put the sensor in the groove keeping the head of the screw in sight
- D.** When the reading position has been found, tighten the screw

Instructions for removal:

- E.** Loosen the screw and apply pressure on the back fixing element
- F.** At the same time lift the sensor using the cable for help
- G.** Rotate the sensor by 90°
- H.** Remove the sensor from the groove

UTILIZZO DEI SENSORI E STAFFE DI MONTAGGIO

usage of sensors and mounting brackets

CILINDRO	STAFFA [mounting bracket]
microcilindri ISO 6432 minicylinders ISO 6432	ø10 : 26.039.0 ø12 : 26.040.0 ø16 : 26.041.0 ø20 : 26.042.0 ø25 : 26.229.0
cilindri tondi round cylinders	ø32 : 26.230.0 ø40 : 26.231.0 ø50 : 26.232.0
cilindri compatti compact cylinders	su cava a T : montaggio diretto su cava a coda di rondine : 26.147.0
cilindri corsa breve short stroke cylinders	26.147.0 
cilindri ISO 6431 ø32 ... 125	montaggio diretto direct mounting
cilindri ISO 6431 ø160-200	26.219.2
cilindri ad asta gemellata twin rod cylinders	montaggio diretto direct mounting

La tabella a lato indica per quali tipi di cilindro si possono utilizzare i sensori di cui alle pagine 532-533, specifica se e quali staffe di montaggio devono essere utilizzate e ne fornisce il codice di ordinazione. Le staffe di montaggio vanno ordinate separatamente.

I nostri sensori possono essere utilizzati anche su cilindri con profilo diverso dal nostro standard. Per le staffe di fissaggio vedi pagina seguente.

The table shows for which types of cylinder the sensors on pages 532-533 can be used. It indicates also whether a mounting bracket must be used, and gives the order code. Mounting brackets must be ordered separately.

Our sensors can be mounted also on cylinders with profile different from our standard. For mounting brackets see the following page.

staffa per cilindri ISO 6431 ø160-200

mounting bracket for cylinders ISO 6431 ø160-200

26.219.2

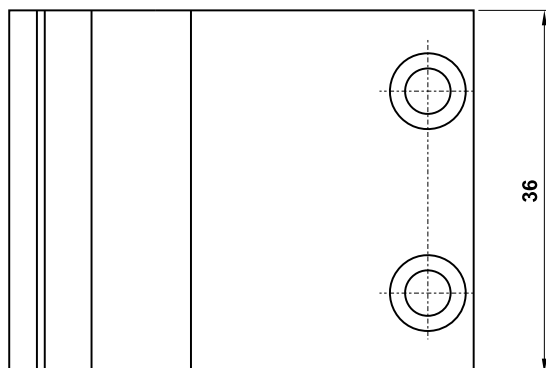
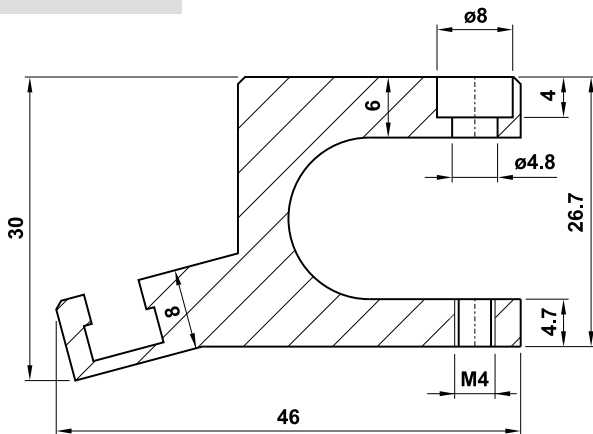

staffe per microcilindri ISO 6432 e cilindri tondi

mounting brackets for minicylinders ISO 6432 and round cylinders

- ø10 : 26.039.0 (materiale plastico - plastic material)
- ø12 : 26.040.0 (materiale plastico - plastic material)
- ø16 : 26.041.0 (materiale plastico - plastic material)
- ø20 : 26.042.0 INOX
- ø25 : 26.229.0 INOX
- ø32 : 26.230.0 INOX
- ø40 : 26.231.0 INOX
- ø50 : 26.232.0 INOX

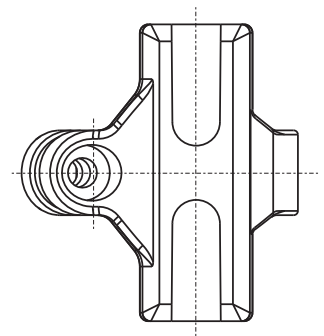
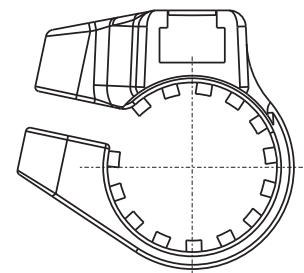

staffe per cilindri con profilo Mickey Mouse

mounting brackets for cylinders with Mickey Mouse profile

26.194.3

ø32 ... 63

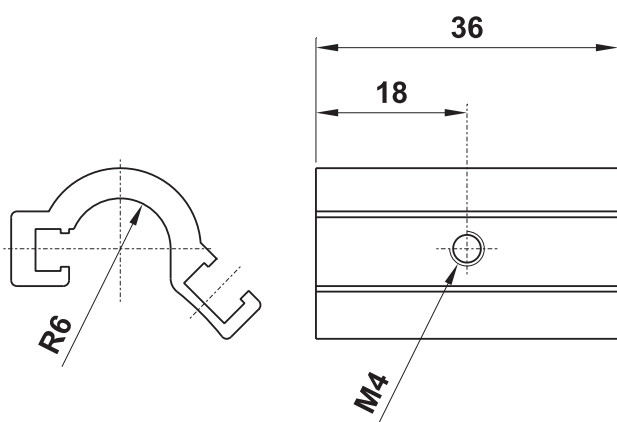
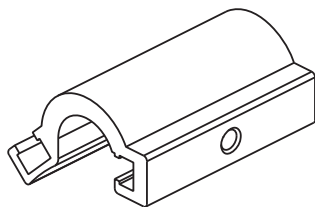

26.145.0

ø80-100

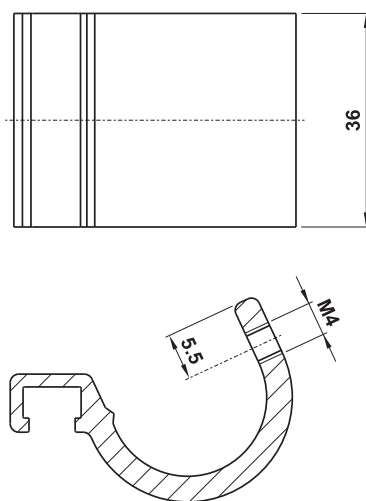
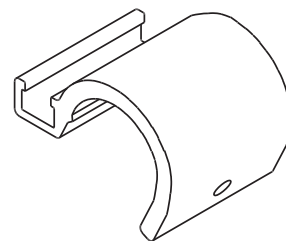

staffe per cilindri con tubo tondo e tiranti

mounting brackets for cylinders with round profile and tie-rods

26.195.0

ø32 ... 63

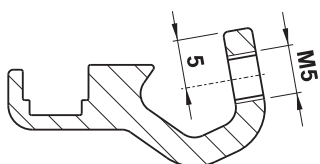
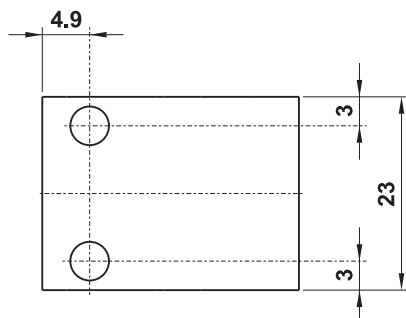
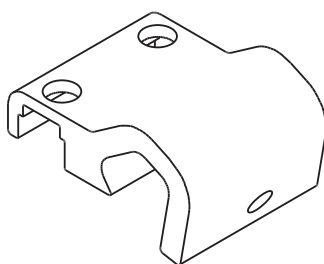

26.196.3

ø80-100

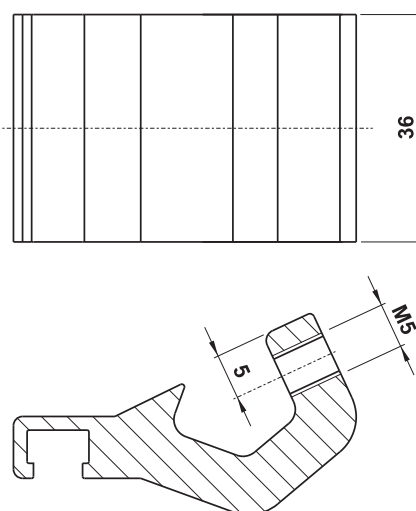
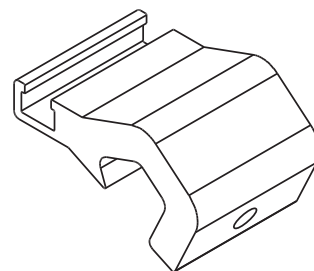

staffe per cilindri senza stelo

mounting brackets for rodless cylinders

35.048.2

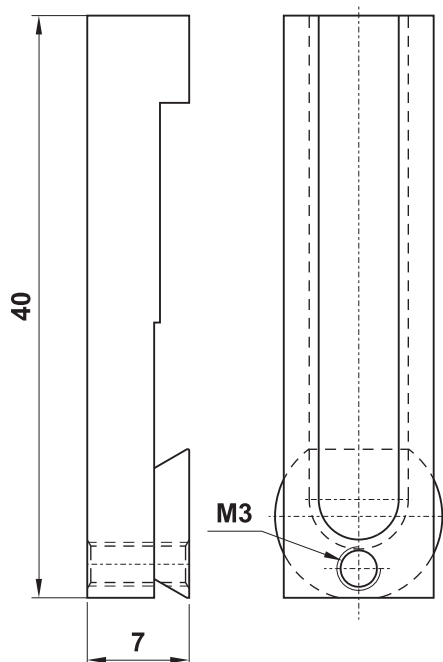
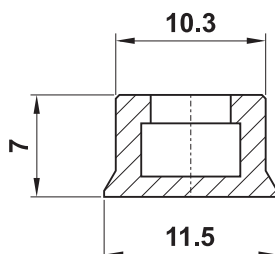

Per il montaggio sul profilo camicia inserire prima la staffa nella apposita cava porta sensore e quindi inserire il sensore nella staffa bloccandolo con il grano.

To assemble the sensor in the cylinder profile, insert first the bracket in the profile groove, and then insert the sensor in the bracket. Fix the sensor by the nut.