

cilindri corsa breve

short stroke cylinders

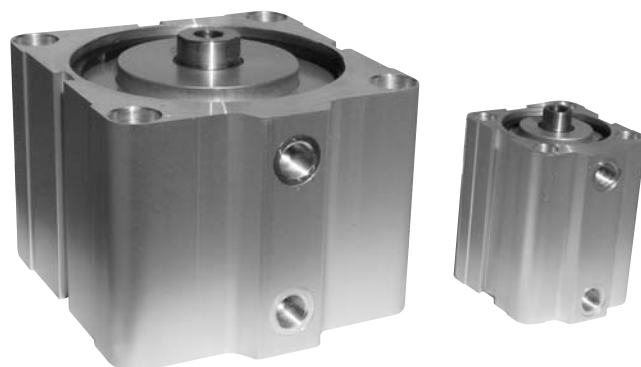

- **Dimensioni di ingombro ridotte**
Reduced external dimensions
- **Grande affidabilità e lunga durata**
High reliability and long life time
- **Versione magnetica standard**
Standard magnetic version
- **Esecuzioni e corse speciali a richiesta**
Special versions and strokes on request



Materiali

Camicia: alluminio

Stelo: C45 cromato o INOX AISI 304

Testate: alluminio con boccola guida stelo

Pistone: alluminio

Guarnizioni: NBR o VITON

Guarnizione stelo: poliuretano o VITON

Magnete: neodimio fino all'alesaggio 25
plastroferrite dall'alesaggio 32 al 100

Materials

Barrel: aluminium

Piston-rod: C45 (chromium plated) or stainless steel

End-cups: aluminium with rod guide

Piston: aluminium

Sealings: NBR or VITON

Piston-rod sealing: polyurethane or VITON

Magnet: neodymium from bore 16 to 25
magnetic iron compound from bore 32 to 100

Pressione di esercizio <i>Working pressure</i>	max 10 bar max 1 MPa
Temperatura di esercizio <i>Temperature range</i>	NBR: max +60°C VITON: max +110°C
Alesaggi <i>Bores</i>	16; 20; 25; 32; 40; 50; 63; 80; 100 mm
Corse <i>Strokes</i>	5 ... 100 mm
Fluido <i>Fluid</i>	Aria filtrata 50µ con o senza lubrificazione 50µ filtered, lubricated or non lubricated air



chiave di codifica

key to codes

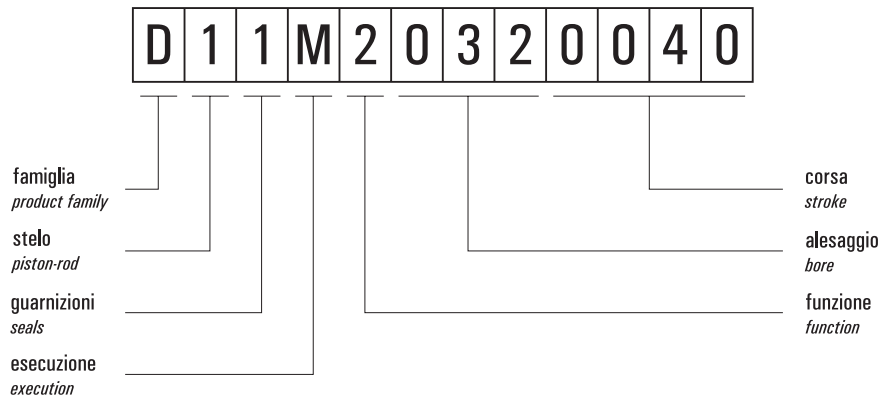

Famiglia *[product family]*

D cilindri corsa breve *[short stroke cylinders]*

Stelo *[piston-rod]*

1 C45 cromato *[C45 chromium plated]*

2 INOX *[stainless steel]*

Guarnizioni *[seals]*

1 NBR

2 tutte le guarnizioni in VITON
[all seals in VITON]

3 guarnizioni dello stelo in VITON *[rod seals in VITON]*

Esecuzione *[execution]*

M magnetico *[magnetic]*

Funzione *[function]*

1 semplice effetto non ammortizzato molla anteriore
[single acting front spring without pneumatic cushioning]

2 doppio effetto non ammortizzato
[double acting without pneumatic cushioning]

3 semplice effetto non ammortizzato molla posteriore
[single acting back spring without pneumatic cushioning]

4 doppio effetto non ammortizzato stelo passante
[double acting without pneumatic cushioning, with passing-through rod]

4

cilindri corsa breve

short stroke cylinders



disegno valido dall'alesaggio 32 all'alesaggio 100
the drawing is valid from bore 32 to bore 100

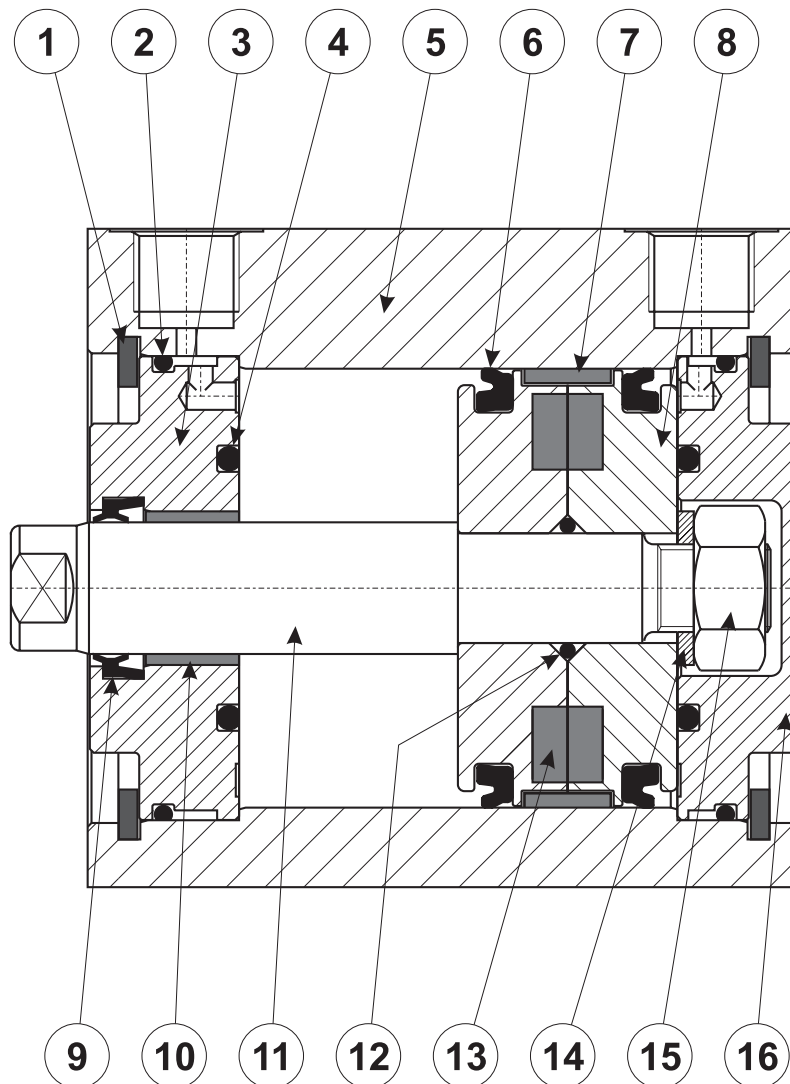

1. Anello SEEGER per fissaggio testata
2. O-Ring per tenuta testata: NBR o VITON
3. Testata anteriore: alluminio
4. O-Ring paracolpi: NBR o VITON
5. Camicia: alluminio profilato, calibrato e anodizzato
6. Guarnizione a labbro per pistone: NBR o VITON
7. Anello guida per pistone: bronzo PTFE
8. Pistone: alluminio
9. Guarnizione stelo: POLIURETANO o VITON
10. Boccola guida: materiale autolubrificante
11. Stelo: acciaio C45 cromato o INOX AISI 304
12. O-Ring per tenuta pistone: NBR o VITON
13. Magnete: plastoferrite
14. Rondella piana
15. Dado per bloccaggio stelo
16. Testata posteriore: alluminio

cilindri corsa breve

short stroke cylinders



versioni disponibili

available versions

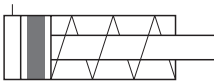
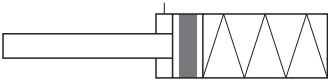
semplice effetto molla anteriore <i>single acting front spring</i> magnetico <i>magnetic</i> non ammortizzato <i>without pneumatic cushioning</i>	alesaggio		16	20	25	32	40	50	63	80	100	OPZIONI <i>options</i> Lo standard è evidenziato in grigio <i>The standard is marked with grey background</i>			
	corsa	bore											stroke		
	5					X	X	X	X	X	X		materiale stelo (piston-rod material) C45 cromato <i>C45 chromium plated</i>	INOX <i>stainless steel</i>	
	10					X	X	X	X	X	X				materiale guarnizioni (seals material) NBR
	25					X	X	X	X	X	X		OPZIONI <i>options</i> Lo standard è evidenziato in grigio <i>The standard is marked with grey background</i>	materiale stelo (piston-rod material) C45 cromato <i>C45 chromium plated</i>	
	30							X	X	X	X				materiale guarnizioni (seals material) NBR
	40												OPZIONI <i>options</i> Lo standard è evidenziato in grigio <i>The standard is marked with grey background</i>	materiale stelo (piston-rod material) C45 cromato <i>C45 chromium plated</i>	
	50														materiale guarnizioni (seals material) NBR
	75												OPZIONI <i>options</i> Lo standard è evidenziato in grigio <i>The standard is marked with grey background</i>	materiale stelo (piston-rod material) C45 cromato <i>C45 chromium plated</i>	
	100														materiale guarnizioni (seals material) NBR
semplice eff. molla posteriore <i>single acting back spring</i> magnetico <i>magnetic</i> non ammortizzato <i>without pneumatic cushioning</i>	alesaggio		16	20	25	32	40	50	63	80	100	OPZIONI <i>options</i> Lo standard è evidenziato in grigio <i>The standard is marked with grey background</i>			
	corsa	bore											stroke		
	5					X	X	X	X	X	X		materiale stelo (piston-rod material) C45 cromato <i>C45 chromium plated</i>	INOX <i>stainless steel</i>	
	10					X	X	X	X	X	X				materiale guarnizioni (seals material) NBR
	25					X	X	X	X	X	X		OPZIONI <i>options</i> Lo standard è evidenziato in grigio <i>The standard is marked with grey background</i>	materiale stelo (piston-rod material) C45 cromato <i>C45 chromium plated</i>	
	30							X	X	X	X				materiale guarnizioni (seals material) NBR
	40												OPZIONI <i>options</i> Lo standard è evidenziato in grigio <i>The standard is marked with grey background</i>	materiale stelo (piston-rod material) C45 cromato <i>C45 chromium plated</i>	
	50														materiale guarnizioni (seals material) NBR
	75												OPZIONI <i>options</i> Lo standard è evidenziato in grigio <i>The standard is marked with grey background</i>	materiale stelo (piston-rod material) C45 cromato <i>C45 chromium plated</i>	
100											materiale guarnizioni (seals material) NBR				tutte in VITON <i>all seals in VITON</i>

cilindri corsa breve

short stroke cylinders



versioni disponibili

available versions

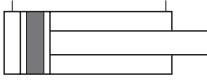
doppio effetto <i>double acting</i> magnetico <i>magnetic</i> non ammortizzato <i>without pneumatic cushioning</i>	alesaggio		16	20	25	32	40	50	63	80	100	OPZIONI <i>options</i> Lo standard è evidenziato in grigio <i>The standard is marked with grey background</i>			
	corsa	bore											stroke		
	5	X	X	X	X	X	X	X	X	X	X		materiale stelo (piston-rod material) C45 cromato <i>C45 chromium plated</i>	INOX <i>stainless steel</i>	
	10	X	X	X	X	X	X	X	X	X	X				
	25	X	X	X	X	X	X	X	X	X	X				
	30	X	X	X	X	X	X	X	X	X	X				
	40	X	X	X	X	X	X	X	X	X	X				
	50		X	X	X	X	X	X	X	X	X				
	75							X	X	X					
	100								X	X					
	doppio effetto <i>double acting</i> magnetico <i>magnetic</i> non ammortizzato <i>without pneumatic cushioning</i> stelo passante <i>passing-through rod</i>	5	X	X	X	X	X	X	X	X	X	X			materiale stelo (piston-rod material) C45 cromato <i>C45 chromium plated</i>
10		X	X	X	X	X	X	X	X	X	X				
25		X	X	X	X	X	X	X	X	X	X				
30		X	X	X	X	X	X	X	X	X	X				
40		X	X	X	X	X	X	X	X	X	X				
50			X	X	X	X	X	X	X	X	X				
75								X	X	X					
100									X	X					
OPZIONI <i>options</i> Lo standard è evidenziato in grigio <i>The standard is marked with grey background</i>		materiale guarnizioni (seals material)		NBR		tutte in VITON <i>all seals in VITON</i>		guarnizioni stelo in VITON <i>rod seals in VITON</i>							

cilindri corsa breve

short stroke cylinders



VERSIONE NORMALE - alesaggio 16, 20, 25

Normal version - bore 16, 20, 25

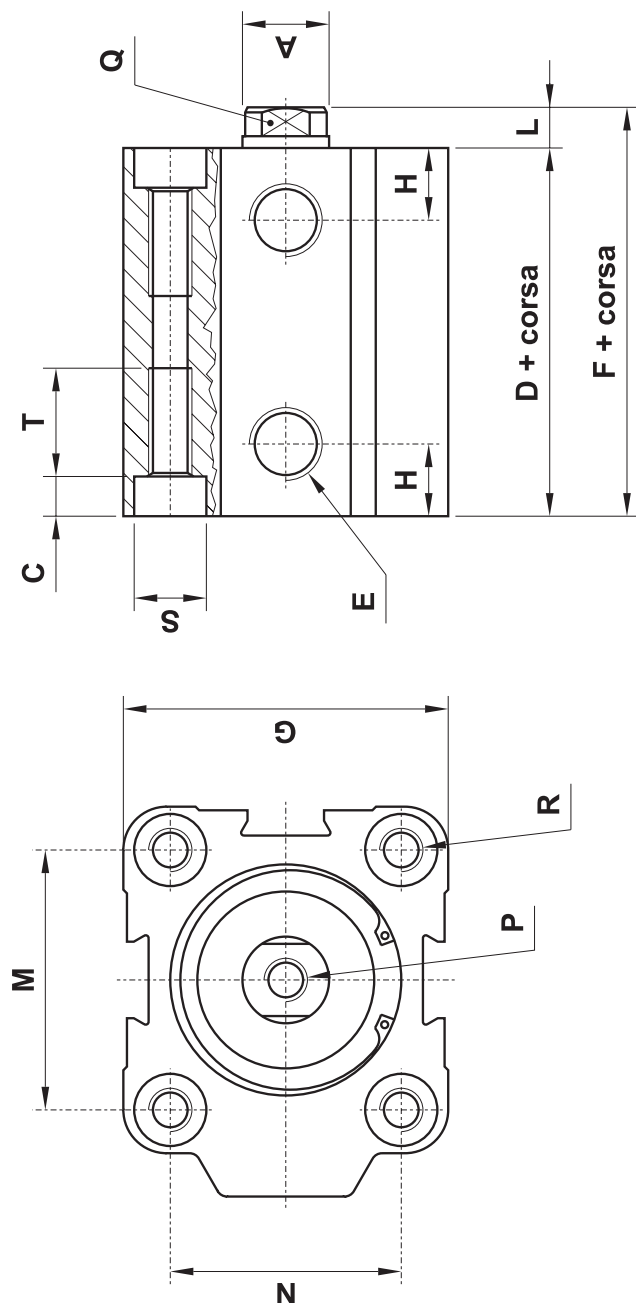

Ø	A	C	D	E	F	G	H	L	M	N	P	Q	R	S	T
16	ø8	3.5	36	M5	41.5	28	8	5.5	20	20	M5	CH 7	M4	ø6	10
20	ø10	4.5	36	M5	41.5	32	8.5	5.5	22	22	M5	CH 8	M5	ø7	12
25	ø10	4.5	38	G1/8"	43.5	38	9	5.5	28	26	M5	CH 8	M5	ø7	12

cilindri corsa breve

short stroke cylinders



VERSIONE NORMALE - alesaggio 32, 40, 50, 63, 80, 100

Normal version - bore 32, 40, 50, 63, 80, 100

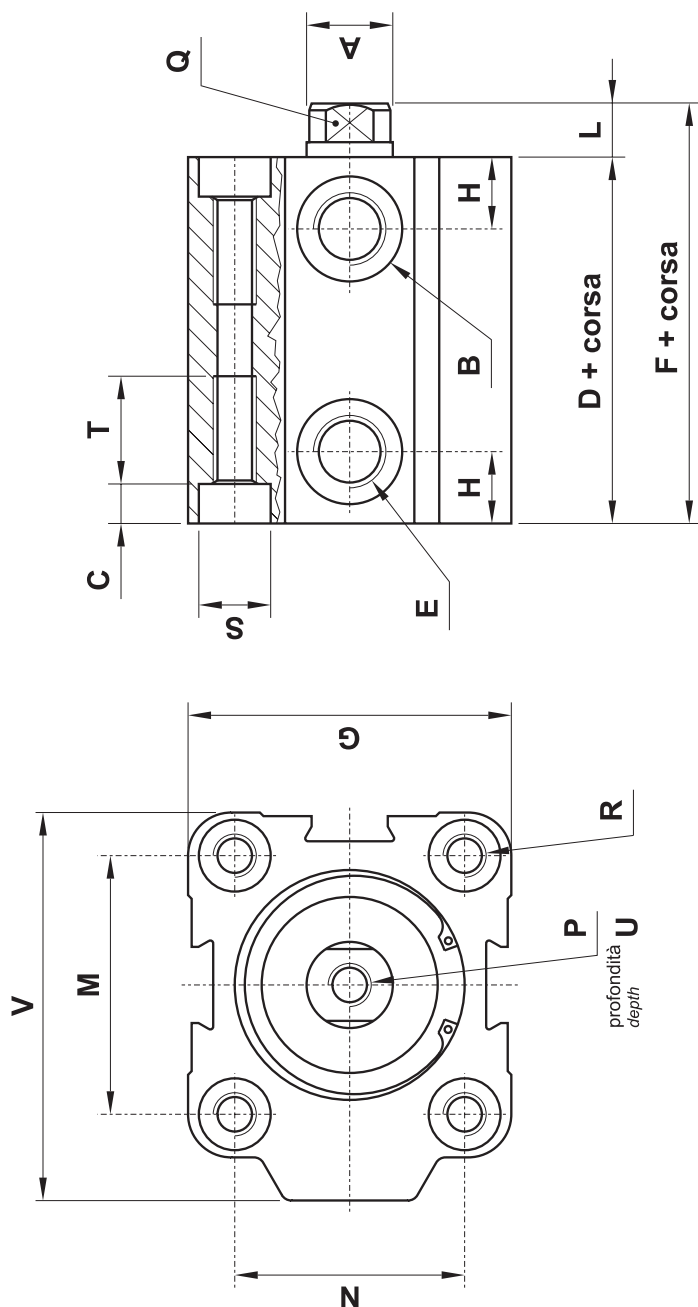

Ø	A	B	C	D	E	F	G	H	L	M	N	P	Q	R	S	T	U	V
32	Ø12	Ø14	5.5	46.2	G1/8"	53.2	45	9	7	36	32	M8	CH 10	M6	Ø9	15	13.5	54
40	Ø12	Ø14	5.5	46.2	G1/8"	53.2	54.5	10	7	40	40	M8	CH 10	M6	Ø9	15	13.5	60
50	Ø16	Ø14	6.5	50	G1/8"	58	65	11.5	8	50	50	M10	CH 13	M8	Ø11	20	16	72.5
63	Ø16	Ø14	8.5	53	G1/8"	61	80	11.5	8	62	62	M10	CH 13	M10	Ø14	20	16	88
80	Ø20	Ø19	8.5	56.4	G1/4"	66.2	100	13.8	9.8	82	82	M10	CH 17	M10	Ø14	22.5	20	110
100	Ø25	Ø19	11	67	G1/4"	76.8	124	17	9.8	103	103	M12	CH 22	M12	Ø17	24	24	134

VERSIONE CON STELO PASSANTE - alesaggio 16, 20, 25

Version with passing-through rod - bore 16, 20, 25

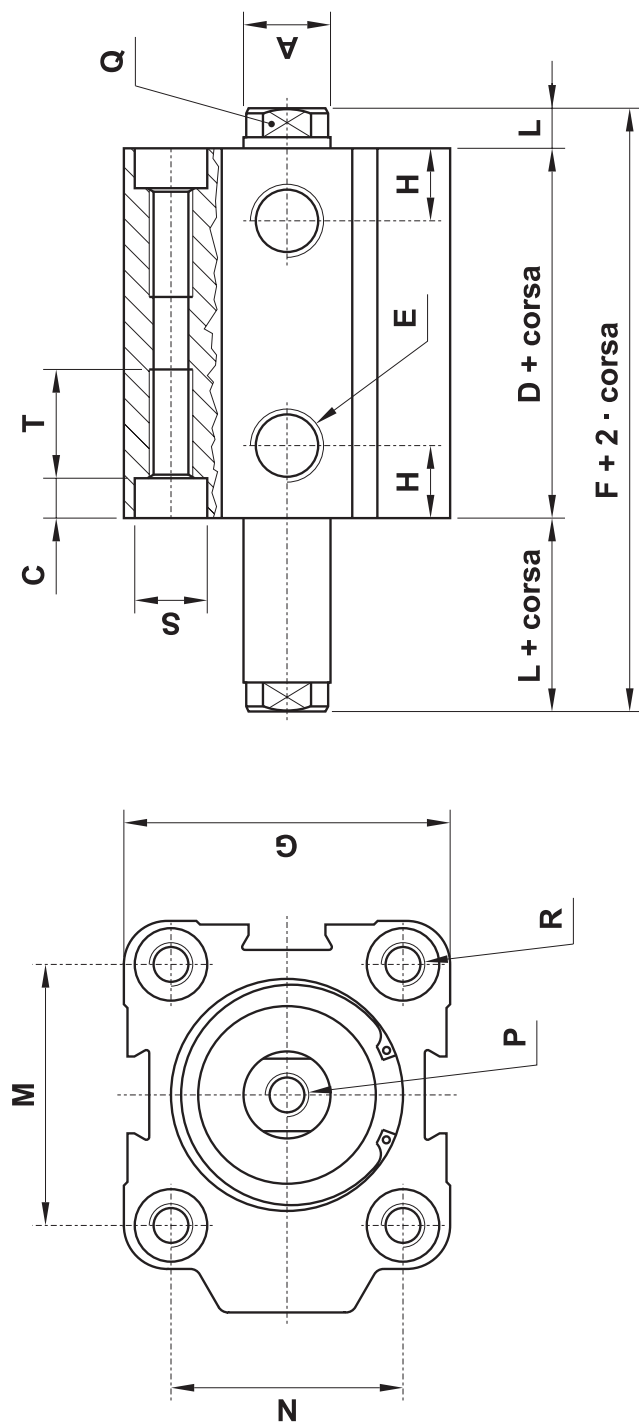

Ø	A	C	D	E	F	G	H	L	M	N	P	Q	R	S	T
16	ø8	3.5	36	M5	47	28	8	5.5	20	20	M5	CH 7	M4	ø6	10
20	ø10	4.5	36	M5	47	32	8.5	5.5	22	22	M5	CH 8	M5	ø7	12
25	ø10	4.5	38	G1/8"	49	38	9	5.5	28	26	M5	CH 8	M5	ø7	12

cilindri corsa breve

short stroke cylinders



VERSIONE CON STELO PASSANTE - alesaggio 32, 40, 50, 63, 80, 100

Version with passing-through rod - bore 32, 40, 50, 63, 80, 100

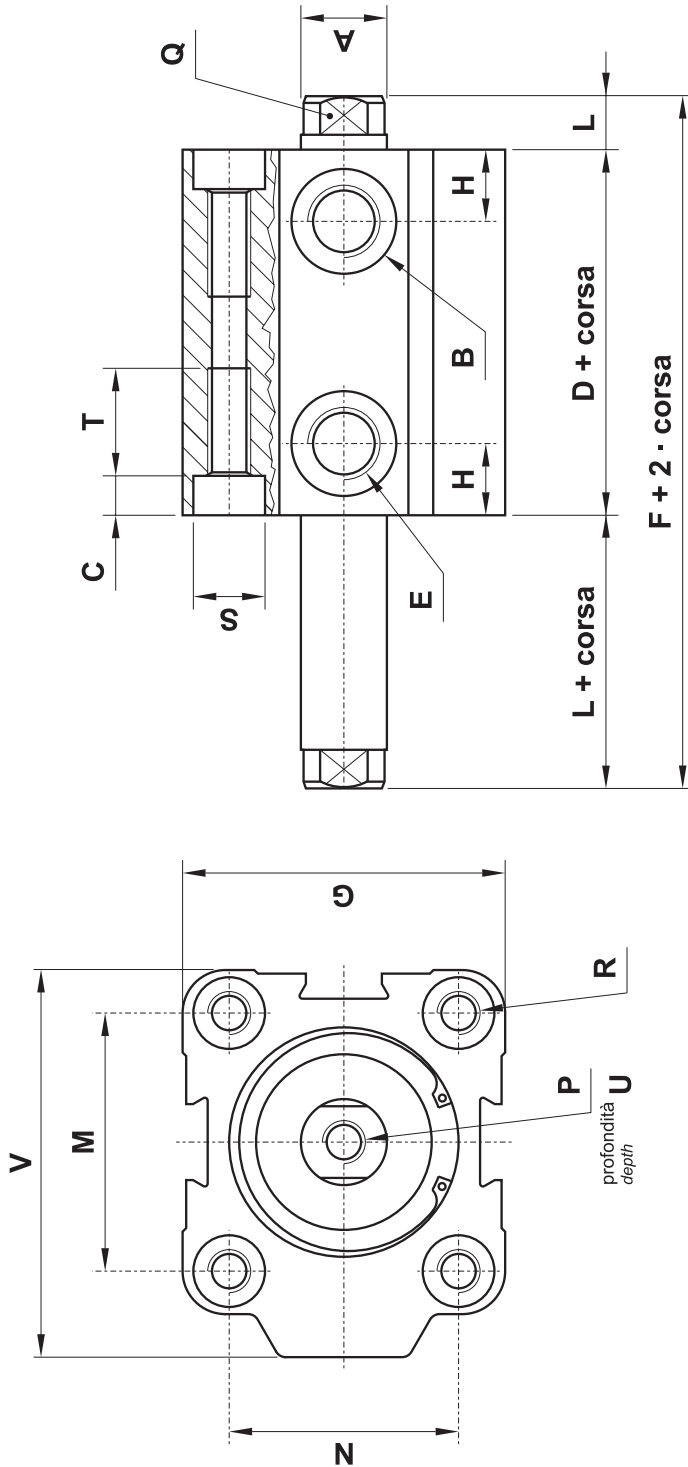

Ø	A	B	C	D	E	F	G	H	L	M	N	P	Q	R	S	T	U	V
32	Ø12	Ø14	5.5	46.2	G1/8"	60.2	45	9	7	36	32	M8	CH 10	M6	Ø9	15	13.5	54
40	Ø12	Ø14	5.5	46.2	G1/8"	60.2	54.5	10	7	40	40	M8	CH 10	M6	Ø9	15	13.5	60
50	Ø16	Ø14	6.5	50	G1/8"	66	65	11.5	8	50	50	M10	CH 13	M8	Ø11	20	16	72.5
63	Ø16	Ø14	8.5	53	G1/8"	69	80	11.5	8	62	62	M10	CH 13	M10	Ø14	20	16	88
80	Ø20	Ø19	8.5	56.4	G1/4"	76	100	13.8	9.8	82	82	M10	CH 17	M10	Ø14	22.5	20	110
100	Ø25	Ø19	11	67	G1/4"	86.6	124	17	9.8	103	103	M12	CH 22	M12	Ø17	24	24	134



kit guarnizioni di ricambio

seals kit

MAGNETICO, guarnizioni standard

normale			stelo passante <i>[passing-through rod]</i>		
per alesaggio <i>for bore</i>	sigla <i>part number</i>	codice <i>code</i>	per alesaggio <i>for bore</i>	sigla <i>part number</i>	codice <i>code</i>
16	GD016	22.100.2	16	GD016P	22.110.2
20	GD020	22.101.2	20	GD020P	22.111.2
25	GD025	22.102.2	25	GD025P	22.112.2
32	GD032	22.103.2	32	GD032P	22.113.2
40	GD040	22.104.2	40	GD040P	22.114.2
50	GD050	22.105.2	50	GD050P	22.115.2
63	GD063	22.106.2	63	GD063P	22.116.2
80	GD080	22.107.2	80	GD080P	22.117.2
100	GD100	22.108.2	100	GD100P	22.118.2

MAGNETICO, guarnizioni VITON

normale			stelo passante <i>[passing-through rod]</i>		
per alesaggio <i>for bore</i>	sigla <i>part number</i>	codice <i>code</i>	per alesaggio <i>for bore</i>	sigla <i>part number</i>	codice <i>code</i>
16	GD016V	22.120.2	16	GD016PV	22.130.2
20	GD020V	22.121.2	20	GD020PV	22.131.2
25	GD025V	22.122.2	25	GD025PV	22.132.2
32	GD032V	22.123.2	32	GD032PV	22.133.2
40	GD040V	22.124.2	40	GD040PV	22.134.2
50	GD050V	22.125.2	50	GD050PV	22.135.2
63	GD063V	22.126.2	63	GD063PV	22.136.2
80	GD080V	22.127.2	80	GD080PV	22.137.2
100	GD100V	22.128.2	100	GD100PV	22.138.2

4

dado per fissaggio in cava

fixing nut

Permette di fissare un cilindro a parete o di fissare sul cilindro le interfacce per valvole, di cui alle pagine 127 e 171. È utilizzabile anche per i cilindri ISO 6431 fino al $\varnothing 125$ e per i cilindri compatti.

It can be used to fix a cylinder on the side or to mount on the cylinder an interface for valves (see page 127 and 171). It can be used also for ISO 6431 cylinders (up to bore 125) and for compact cylinders.

sigla part number	codice order code	A
DCCB 16/32	26.156.0T	M5
DCCB 32/100	26.157.0T	M6

