

PiloTREK

W-200

2-wire 80 GHz non-contact radar
level transmitters

User's and programming manual
1st edition



Manufacturer:

NIVELCO Process Control Co.
H-1043 Budapest, Dugonics u. 11.

Tel.: +36-1-889-0100

E-mail: sales@nivelco.com ■ www.nivelco.com



BASIC CONCEPTS AND ELEMENTS

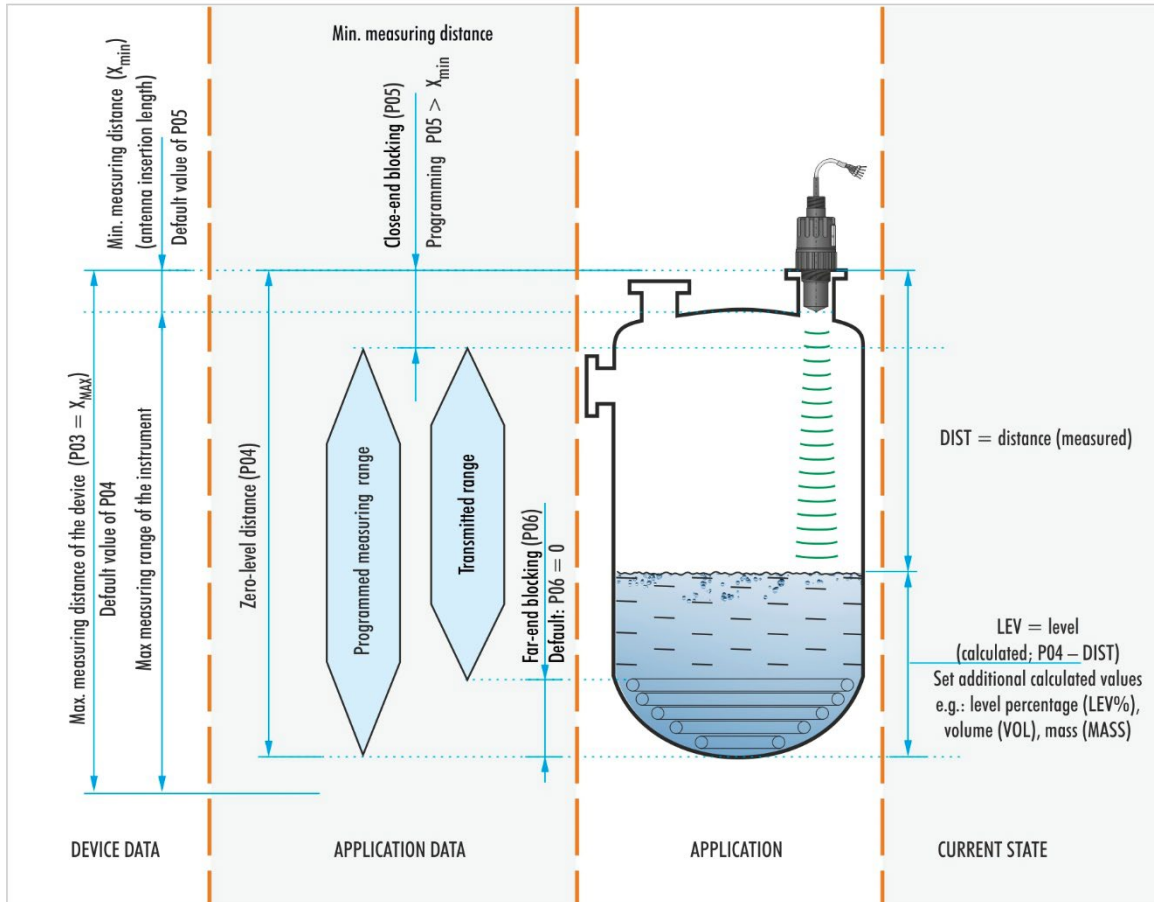

TABLE OF CONTENTS

1.INTRODUCTION	5	5.8.Open-channel flow measurement.....	31
2.ORDER CODES (NOT ALL COMBINATIONS ARE AVAILABLE)	6	5.9.Output Conversion Table (OCT) programming.....	38
3.TECHNICAL DATA	7	5.10.Service diagnostic parameters (read only).....	Hiba! A könyvjelző nem létezik.
3.1.General Data.....	7	5.11.Flow measurement control parameters (read only)	Hiba! A könyvjelző nem létezik.
3.2.Type-dependent data.....	Hiba! A könyvjelző nem létezik.	5.12.Output control parameters (read only).....	Hiba! A könyvjelző nem létezik.
<i>Linearity error</i>	7	5.13.Hardware / Software versions (read only).....	Hiba! A könyvjelző nem létezik.
3.3.Dimensions.....	8	6.TROUBLESHOOTING	HIBA! A KÖNYVJELZŐ NEM LÉTEZIK.
3.4.Accessories.....	9	6.1.Status and error indication in HART communication	Hiba! A könyvjelző nem létezik.
3.5.Conditions of safe operation.....	9	7.EVIEW2 INSTRUCTIONS	43
3.6.Repair, maintenance, and storage conditions.....	9	7.1.Device Status Window.....	Hiba! A könyvjelző nem létezik.
3.7.Firmware update.....	10	7.2.Echo Diagram oscilloscope function.....	Hiba! A könyvjelző nem létezik.
4.INSTALLATION	10	7.3.Threshold settings.....	Hiba! A könyvjelző nem létezik.
4.1.Level measurement.....	10	7.4.Threshold mask.....	Hiba! A könyvjelző nem létezik.
4.2.Flow measurement.....	12	7.5.The output conversion table (OCT) – (EView2 OC-Table)	Hiba! A könyvjelző nem létezik.
4.3.Wiring.....	12	7.6.Programming example 1 – configuring level measurement (using EView2)	Hiba! A könyvjelző nem létezik.
4.4.User interfaces.....	13	7.7.Programming example 2 – configuring the current loop output (using EView2).	Hiba! A könyvjelző nem létezik.
4.5.BUS (HART®) communication.....	13	8.PARAMETER LIST	49
4.6.Commissioning and setting up.....	14		
5.PROGRAMMING	15		
5.1.Programming via EView2.....	15		
5.2.Configuring the measurement.....	16		
5.3.Current loop output.....	22		
5.4.Relay output (optional).....	24		
5.5.Digital communication.....	Hiba! A könyvjelző nem létezik.		
5.6.Measurement optimization.....	Hiba! A könyvjelző nem létezik.		
5.7.Volume measurement.....	Hiba! A könyvjelző nem létezik.		



Thank you for choosing a NIVELCO instrument!

1. INTRODUCTION

Application

The new PiloTREK W-200 non-contact radar level transmitters use the most advanced industrial measurement technology, the 80 GHz FMCW radar. The most fundamental advantage of 80 GHz radars compared to lower frequencies (5...12 GHz and 25 GHz) is the smaller antenna size, better focusability, and narrow beam angle.

It uses the latest technology for measuring liquids, masses, emulsions, and other chemicals widely used in, for example, the water industry, food industry, energy industry, pharmaceutical industry, and chemical industry, which provides measurement results with millimeter accuracy.

It can also measure materials prone to vapor formation and liquids with a gas blanket. Since the propagation of millimeter waves does not require a medium, it can also be used in a vacuum.

The device is HART® compatible and can be operated with EView2, PACTware, and MultiCONT universal process controller.

Operating Principle

The PiloTREK W-200 level transmitter is a frequency modulated continuous wave (FMCW) radar operating at 80 GHz (W-band).

Depending on the measured medium, part of the energy of the frequency-modulated wave emitted by the antenna of the level transmitter is reflected from the measured surface.

The electronics module calculates the distance of the reflecting surface from the frequency shift proportional to the flight time of the reflected signal with high accuracy and converts it into a signal proportional to distance, level, or volume. The propagation speed of the millimeter-wave signal in air, gases, and vacuum is virtually the same regardless of temperature and pressure, so these factors do not significantly affect the accuracy of the measurement.

The signal strength of the reflected millimeter waves depends largely on the measured medium's dielectric constant (ϵ_r). Therefore, the maximum measuring distance achieved may decrease accordingly. Choosing an antenna with a larger diameter, thus higher gain, is recommended for measuring mediums with a low dielectric constant.

2. ORDER CODES (NOT ALL COMBINATIONS ARE AVAILABLE)

PiloTREK W P - 2 -

Antenna / housing material	Code	Measurement range	Code	Process connection – lower / upper	Code	Output	Code
PP / PP	A	10 m	1	1" BSP / 1" BSP ⁽¹⁾	2	4...20 mA / HART®	4
PVDF / PVDF	B	20 m	2	1" NPT / 1" BSP ⁽¹⁾	3	4...20 mA + HART® + relay	H
		30 m	3	1½" BSP / 1" BSP ⁽²⁾	4		
				1½" NPT / 1" BSP ⁽²⁾	5		

⁽¹⁾ Only for 10 m (33 ft) measuring range

⁽²⁾ Only for 10 m or 20 m (33 ft or 66 ft) measuring range

3. TECHNICAL DATA

3.1. General

Measured and derived values	Measured value: distance; derived values: level, volume, mass, flow;	
Signal frequency	77...81 GHz (W-band)	
Process / ambient temperature	-40...+80 °C (-40...+176 °F)	
Measuring frequency	~ 1 s	
Resolution	1 mm (.039")	
Process pressure	-1...3 bar (-14.5...43.5 psi)	
Supply voltage	12...36 V DC	
Output	Analog	Output
	Digital	HART® interface, loop resistance ≥ 250 Ω
	Relay (optional)	SPDT 30 V / 1 A DC; 48 V / 0.5 A AC
	Service interface	SAT-504-3 compatible; galvanically isolated; 3.3 V LVDS; max. 100 mA
Seal	EPDM	
Electrical protection	Class I overvoltage protection; (Class III [SELV])	
Ingress protection	IP68	
Electrical connection	4 × 0.5 mm ² shielded Ø6 mm cable × 5 m (up to 30 m); (4 × 22 AWG shielded Ø0.24" cable × 16.4 ft [up to 98.5 ft]); For the relay option: 7 × 0.5 mm ² (22 AWG) shielded cable	

3.2. Type-specific data

	1" / 10 m (33 ft) measuring range WP□-212-□ / WP□-213-□	1½" / 10 m (33 ft) measuring range WP□-214-□ / WP□-215-□	1½" / 20 m (66 ft) measuring range WP□-224-□ / WP□-225-□
Sensor material	PP, PVDF		
Dead zone ⁽¹⁾	0 m (0 ft)		
Maximum measuring range ⁽²⁾	10 m (33 ft)		20 m (66 ft)
Accuracy ⁽³⁾	±5 mm (±0.2")		±2 mm (±0.08")
Beam angle (-3 dB)	12°		7°
Antenna insertion length ⁽⁴⁾	56 mm (2.2")		70 mm (2.75")
Lower process connection	1" BSP / NPT		1½" BSP / NPT
Upper process connection	1" BSP		

⁽¹⁾ Measured from the tip of the antenna.

⁽³⁾ In the case of an ideal reflecting surface.

⁽²⁾ May be limited in the case of low dielectric constant or non-perpendicular or non-planar media.

⁽⁴⁾ Measured from the sealing plane of the process connection.

Linearity error

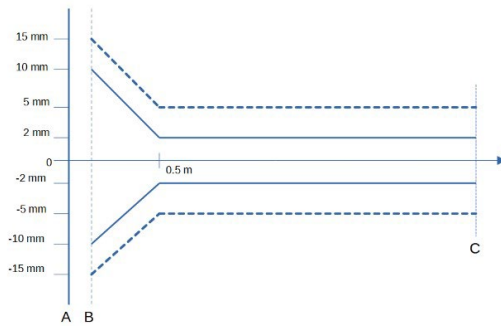

Legend:

----- WP□-212-□ / WP□-213-□ / WP□-214-□ / WP□-215-□
 _____ WP□-224-□ / WP□-225-□

- A. Plane of the device's process connection
- B. The minimum measuring distance (X_m), below which the radar cannot measure, due to the insertion length of the antenna
- C. Maximum measuring distance (X_M)

3.3. Dimensions

1" integrated version with plastic housing
 WP□-212-□ / WP□-213-□

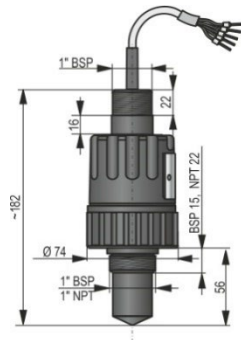

1½" integrated version with plastic housing
 WP□-210-□ / WP□-220-□

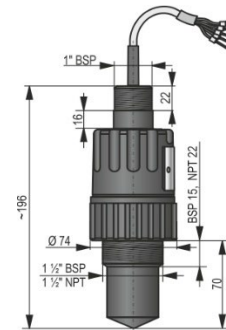

3.4. Accessories

- Warranty card
- User and programming manual
- EU Declaration of Conformity
- Two flat nuts for the upper 1" BSP thread
- One O-ring

3.5. Conditions of safe operation

Compliance with technological process conditions

Make sure that all parts of the equipment that come into contact with the measured medium (sensor, seal, and fittings) meet the requirements of the process, such as the pressure and temperature generated during the process, as well as the chemical effects of the medium and the technologies used.

3.6. Repair, maintenance, and storage conditions

The **PiloTREK W-200** does not require regular maintenance. However, there may be cases where the sensor head needs to be cleaned of material deposits. Clean the device carefully, without scratching or pressing the radiating surface.

All repairs, whether covered by warranty or not, must be carried out by NIVELCO.

The device returned for repair must be cleaned by the user, all chemical deposits must be removed, and the device must be disinfected before sending it back. In addition, the return package must include a properly filled [Returned Equipment Handling Form](#) (B0407/C, download it from our website), in which the sender declares that the device is free of all contamination and substances hazardous to health.

If the device is not used, store it within the ambient temperature specified in the technical data, with a maximum humidity of 98%.



The cable extending from the device must be fixed and relieved of any tension!



Use a junction box corresponding to the electrical classification of the environment to connect the wires!



The device may only be powered from a Category 2 (SELV/PELV) power supply unit!

3.7. Firmware update

NIVELCO continuously maintains and improves the device's firmware, considering user feedback. If necessary, the firmware of the device can be updated using the built-in program update communication port.

Contact the manufacturer about NiFlash Light that is required for the update

4. INSTALLATION

4.1. Level measurement

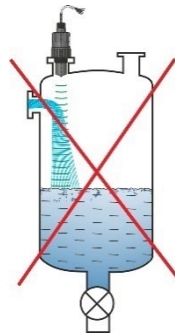
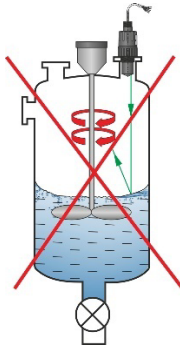
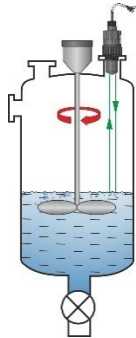
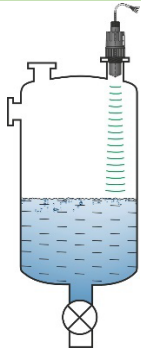

LOCATION

The optimal location of the PiloTREK (cylindrical container) is on the radius $r = (0.3...0.5)$. In any case, it is advisable to consider the radiation cone angle.

The surface of the liquid must be perpendicular to the axis of the device.

Never place the device near the inlet. Improper placement may cause malfunctions.

OBSTACLES

Objects (cooling pipe, ladder, stiffening structural element, thermometer, etc.) intruding into the beam must be avoided.



Up to 4 interfering echoes can be blocked by programming in the PiloTREK W-200 threshold settings!

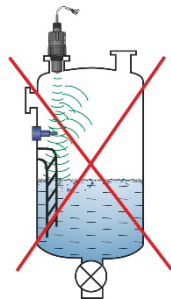

DEVICE ANGLE

The radiating surface of the sensor must be parallel to the measured surface within a deviation of $\pm 2...3^\circ$.

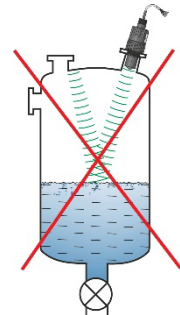

GAS / VAPOR

In a closed (especially outdoor, exposed to sunlight) container, vapors/gases above the liquid can reduce the penetrating ability of the millimeter-wave signal.

EMPTY CONTAINER

Especially in the case of tanks with a convex or conical bottom, or in the case of tanks with equipment (e.g., heating element, mixing paddle) at the bottom of the tank, the device may indicate an incorrect level when completely emptied. The reason for this is that the tank bottom or the objects located at the bottom of the tank scatter and reflect the emitted millimeter waves to a certain extent, and the scattered radiation of a lower signal level in the tank can interfere with itself.

These interfering objects and a convex or conical tank bottom must be covered by at least 100 mm (3.9") of the liquid for a reliable measurement.

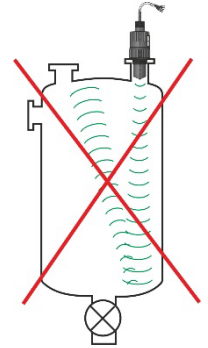

TEMPERATURE

The sensor must be protected from direct sunlight to avoid the temperatures higher than permitted.

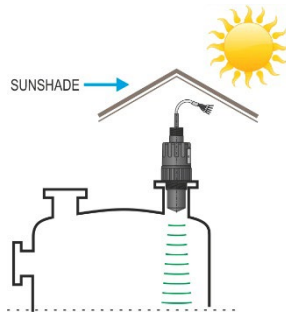

FOAM

Foam on the measured surface may defeat the millimeter-wave level measurement. Therefore, if possible, the sensor must be installed in a place under which foam formation is the least.

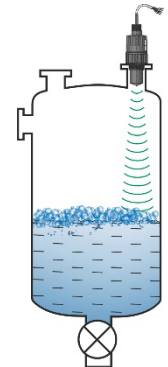

4.2. Flow measurement

- The device can measure flow in open channels with the flumes described in Chapter 5.8.
- The sensor must be placed as close to the surface as the maximum measured level and the dead zone of the sensor allow.
- The sensor must be placed in the longitudinal axis of the flume, at a location determined by the characteristics of the flume. This point is marked on the Parshall flumes sold by NIVELCO.
- Foam may form on top of the flowing liquid, which may compromise the measurement. Therefore, the liquid's surface opposite the sensor face must be exposed for a suitable echo.
- The sensor must be fixed so that its position cannot change.
- The proper construction of the section before and after the measuring channel is extremely important for an accurate measurement.
- The measurement accuracy based on volume flow change depends on the size and shape of the flume (channel, valve) used and the surface of the flowing liquid (rippling, foaming). Therefore, flow measurement accuracy inevitably falls short of level measurement accuracy.
- The sensor must be protected from direct sunlight with a shielding roof to avoid temperatures higher than permitted.

4.3. Wiring

- Check that the terminals of the already installed terminal box are not energized.
- Connect the wires of the device as shown in the diagram. Pay attention to the polarity: (+) brown, (-) white. (For cabling, it is recommended to use $2 \times 0.5 \text{ mm}^2$ ($2 \times 20\text{AWG}$) twisted-pair shielded cable or $5 \times 0.5 \text{ mm}^2$ ($5 \times 20\text{AWG}$) for the optional relay).
- When connecting the shielding, make sure that there is no ground loop.
- After the device is powered on, the necessary programming can be carried out.

Color coding of terminals

- | | | | | |
|-------------|-------------------|--------------|-------|--|
| pink | - C1 relay output | white | - I | Current loop, supply voltage, and HART terminal 1 (polarity-independent) |
| gray | - CC relay output | brown | - I | Current loop, supply voltage, and HART terminal 2 (polarity-independent) |
| blue | - C2 relay output | black | - GND | Technical ground and shielding point |

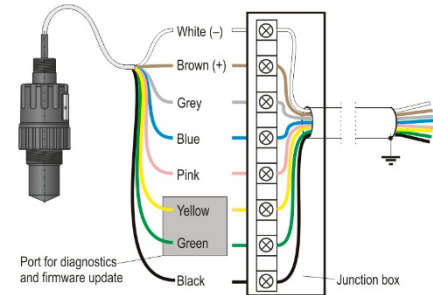
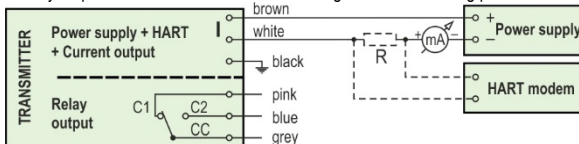

Extending the cable:

It is recommended to use a terminal box to extend the cable. The shielding must be connected to the shielding of the extension cable and grounded at the processing device.

The green and yellow wires are the connection points of the "Service interface" (see next chapter). They are not required for using the device. They are covered with a shrink tube at the cable end by default.

4.4. User interfaces

The device can be set (programmed) using the following tools

MultiCONT universal process controller	Available for purchase.
HART® USB modem SAT-504-0, -1, -2	Available for purchase. See “5.1. Programming with EView2”
HART® USB modem SAT-504-3, -4	Available for purchase. See “5.1. Programming with EView2.” The firmware of the device can be updated with NiFlash via the service interface. See “3.7. Updating the firmware.”
EView2 software	Download it free of charge here: https://nivelco.com/download#!/software/56

4.5. BUS (HART®) communication

The output of the device can be used as:

- Current loop output and HART®
- Multidrop, HART® protocol

The EView2 program and the MultiCONT universal process controller support the both modes. In accordance with the Rosemount Standard, HART® communication can be used between the PiloTREK as a “slave” and the HART® master as a point-to-point connection.

Communication can be implemented in two modes:

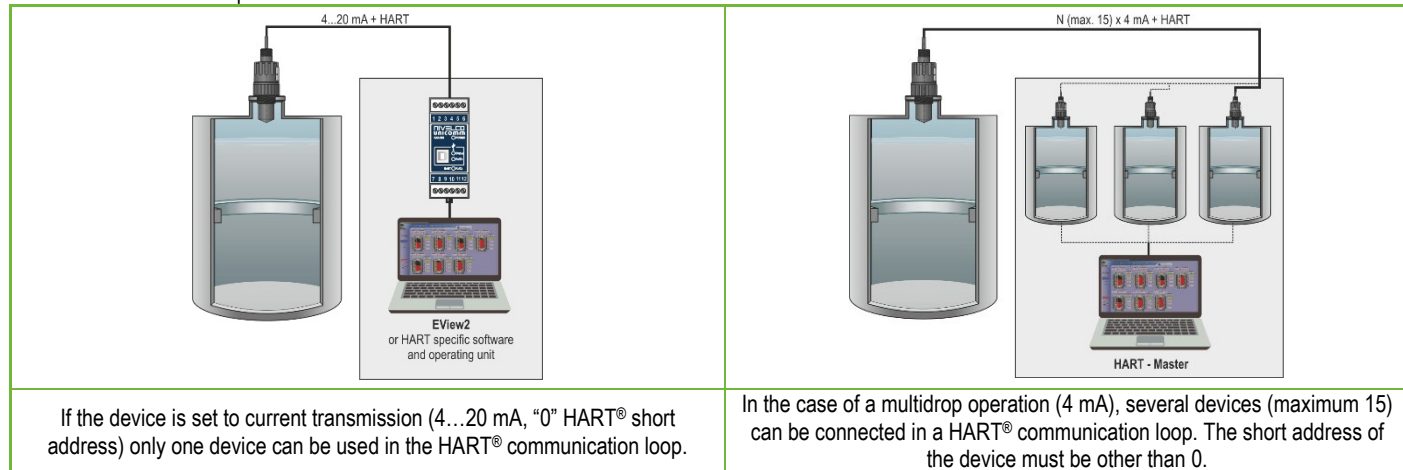

4.6. Commissioning and setting up

When the device is connected correctly, the radar starts up with a current consumption of 3.5 mA after switching on the power supply. After 3...5 s, the ECHO and the COM LED light up together. After another 5...10 s, the transmitted current corresponding to the operating mode appears on the current output. In this case, the device measures with factory settings. The factory default settings are suitable for checking functionality and using the device for simple measurement tasks, but the device's full potential can only be used with the correct programming tailored to the requirements of the measured process. Therefore, to get to know the operational characteristics thoroughly and solve complex measuring tasks, it is necessary to study the chapters about programming.

LED states:

- **ECHO-LED**
 - ON, if the device receives a suitable echo.
 - BLINKS when the device is searching for an echo.
- **COM-LED**
 - FLASHES UP ONCE if there has been a HART message exchange,
 - ON, if the device is in remote programming mode.
 - BLINKS for 4 seconds after the device is switched on: service communication connection can be established during this time. If it continues to blink, it indicates a firmware error.
- **RELAY LED (optional)**
 - ON, when CC-C2 is conducting.
 - OFF, when CC-C1 is conducting.

All parameters of the device have a factory default value, which can be restored later if necessary.

The factory settings of the **PiloTREK W-200** level measuring device are as follows.

- Measurement mode: level (LEV).
- Zero level is assigned to the maximum measuring distance.
- The current loop output is directly proportional to the level.
- 4 mA and 0% are assigned to zero level.
- 20 mA and 100% are assigned to the maximum level (minimum measuring distance).
- The current loop output holds the last value in case of an error.
- Level-following time constant: 10 s.

View of the transmitter neck from above:

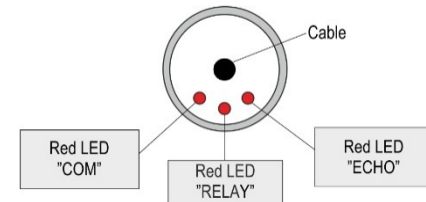

Status signals involving two LEDs:

ECHO LED	COM LED	Number of blinks	Status	Source -bit- (See 6.1.)
Blinking alternately		continuous	Low loop voltage	Bit15, Bit14, Bit11 present at the same time
Flashing up at the same time, then pause, and repeat		2	OCT integrity error	Bit3 or Bit4 or Bit5
		3	Not in use	-
		4	Relay error	Bit13
		5	Not in use	-
		6	NV memory error (EEPROM)	Bit1
		continuous	<ul style="list-style-type: none"> HRP detection failure SIM detection failure 	Bit12

5. PROGRAMMING

The HART interface of the **PiloTREK W-200** lets the user to access and program all device parameters. The parameter set can be accessed in two ways:

- Using a HART modem connected to the sensing resistor in the current loop and the **EView2** (see Chapter 7. [EView2 instructions](#)) program running on the computer.
- Using NIVELCO's **MultiCONT** multi-channel process controller.

These methods differ in many aspects. This programming guide only discusses the method involving **EView2**.

For detailed information, refer to the descriptions of the particular access methods or the user manuals.

Some rarely used parameters cannot be set directly from the graphical interface. Instead, they can be changed referring to the parameter number at the following path.

EView2 parameter: “Device Settings” → “Advanced Mode” → “Parameters”

5.1. Programming via EView2

If necessary, install the [EView2 HART configuration software](#) (henceforth referred to as EView2) as shown in Chapter 3 in the program's user manual. The software can be downloaded from nivelco.com.

Electrical connections: connect the transmitter to the PC using a HART USB modem (accessory supplied separately). Wiring is detailed in Chapter 5.

Further description and setup examples for using EView2 can be found in Chapter 7.

5.2. Configuring the measurement

P00: d c b a Unit system, default unit

FACTORY DEFAULT: 0000

*If parameter P00 is changed, the device reverts the entire parameter set to the factory default values of the new unit system.
Therefore, all parameters must be set again!*

a	Mode
0	Normal

EView2 parameter: “Device Settings” → “Application” → “Operating mode”

b	Unit (per “c”)	
	Metric (EU)	Imperial (US)
0	m	ft
1	cm	inch
2	mm	inch

EView2 parameter: “Device Settings” → “Application” → “Engineering units”

c	Unit system
0	Metric (EU)
1	Imperial (US)

EView2 parameter: “Device Settings” → “Application” → “Calculation system”

d	Temperature unit
0	°C
1	°F

EView2 parameter: “Device Settings” → “Measurement configuration” → “Temperature”

P01ba defines the source of the primary output value (HART – PV), which also defines the value transmitted on the analog current output. The device automatically selects the measurement mode according to the selected output source. The device measures the level's distance. The other quantities are calculated based on the specified tank parameters and material characteristics.

ba	Output data / measuring mode	Parameter
10	Distance	-
11	Level	P04
12	Volume	P04, P40...45
13	Weight	P04, P32, P40...45
14	Flow	P04, P40...45, P46
15	Empty volume	P04, P40...45, P47
16	Level%	P04
17	Volume%	P04, P40...45

EView2 parameter: "Device Settings" → "Measurement configuration" → "Measurement mode"

**Distance measurement (DIST) /
Level measurement (LEV)**

DIST: Currently measured distance

A: Shortest measurable distance (P05)

H: Longest measurable distance (also the distance to the zero level) (P04)

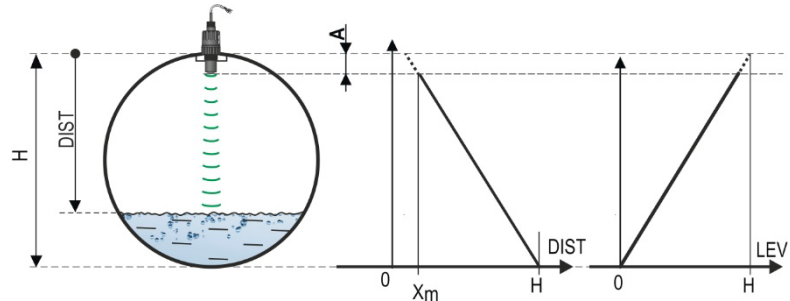

Volume measurement (VOL)

DIST: Currently measured distance

A: Shortest measurable distance

H: Zero-level distance

B: The volume associated with the highest measurable level

C: Total volume of the container

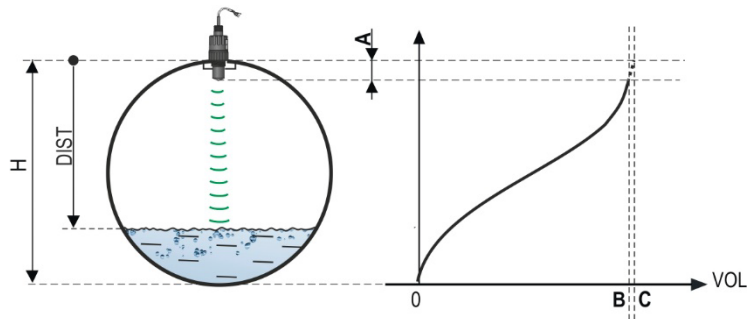

P02: d c b a Output units

FACTORY DEFAULT: 2021

The device calculates the volume, weight, and volume flow over a unit of time using a level-dependent (non-linear) function using **P40** or an output correction table (*OCT*). This parameter also determines the unit of measure for the “Output” column of the *OCT* table. The TOT value in flow measurement mode totalized (total) amount flowed. The distance, level, and temperature units can be selected in parameter **P00**.

a	Weight unit	
	Metric	US
0	kg	lb
1	ton	US ton
2	US ton	metric ton

EView2 parameter: “Device Settings” → “Measurement configuration” → “Mass units”

b	Volume	
	Metric	US
0	liter	gallon
1	hL ⁽¹⁾	ft ³
2	m ³	barrel
3	million liter ⁽¹⁾	million gallon ⁽¹⁾

EView2 parameter: “Device Settings” → “Measurement configuration” → “Volume units”

c	Time
0	second
1	min
2	hour
3	day

EView2 parameter: “Device Settings” → “Measurement configuration” → “Time units”

d	TOT	
	Metric	US
0	liter	gallon
1	hL	ft ³
2	m ³	barrel
3	million liter ⁽¹⁾	million gallon ⁽¹⁾

(1) Its use is not recommended for flow measurement! (In HART transmission, it can only be interpreted together with reading an application-specific code.) Except for MGD.

EView2 parameter: “Device Settings” → “Measurement configuration” → “TOT units”

P03: Maximum detection distance

FACTORY DEFAULT: See X_{max} in the table.

The maximum detection distance measured from the process connection. The device only evaluates level signals within the specified distance. The maximum detection distance is specific to the type. See the X_{max} column of the type-specific measurement distance table below. A smaller value can be set. The minimum value is parameter P05 + 30 centimeters. It is not necessary to set this parameter. The device automatically selects the detection distance based on the zero-level distance specified in P04, within the limits of P03.

Type-specific measuring distance	Minimum X_{min}	Maximum X_{max}
WP□-212-□ / WP□-213-□	0.056 m (2.2")	10 m (32.8 ft)
WP□-214-□ / WP□-215-□	0.070 m (2.76")	10 m (32.8 ft)
WP□-224-□ / WP□-225-□	0.070 m (2.76")	20 m (65.6 ft)

*Measured from the process connection

EView2 parameter: “Device Settings” → “Measurement configuration” → “Sensing distance”

P04: Zero-level distance (container height – H)**FACTORY DEFAULT: See X_{\max} in the table.**

This parameter must be set in all cases, except for distance measurement.

The zero-level distance (**P04**) is the distance between the sealing plane of the process connection and the designated zero level of the level measurement (e.g., the bottom of the tank). The device calculates the level value from the P04 value by subtracting the measured level distance. The device automatically sets the measuring distance within the maximum detection distance (P03). The distance given here is denoted by 'H' in the figures and formulas. The maximum distance that can be measured (X_{\max}) is in the measuring distance table above, depending on the selected type. The set zero-level distance can be greater than the maximum measuring distance but not more than 60 m (200 ft).

Given that the **level measured** by the device is the calculated difference between the **P04 set** for the given application and the **distance (DIST) measured by the device**, it is important to specify the zero-level distance (H) accurately.

EView2 parameter: “Device Settings” → “Measurement configuration” → “Zero-level dist.”

P05: Close-end blocking (dead-zone)**FACTORY DEFAULT: See X_{\min} in the table**

The dead-zone (starting from the process connection of the transmitter) is the range within which the device cannot measure due to its physical limitations (antenna insertion length). This is the minimum measuring distance of the device, and it is type-dependent. See the X_{\min} column of the type-dependent measuring distance table above.

Close-end blocking is the user-defined extension of the dead zone, within which the device does not consider any echoes. This, e.g., enables the exclusion of objects interfering with the measurement close to the sensor. Close-end blocking cannot be less than X_{\min} .

EView2 parameter: “Device Settings” → “Measurement configuration” → “Minimum(P05)”

P06: Far-end blocking**FACTORY DEFAULT: 0.0**

In parameter **P06**, we can specify a level value below which the output will no longer follow any further level decrease. Far-end blocking is used when objects at the bottom of the tank (mixer, heating coil, hopper, etc.) cause measurement uncertainty in this range, e.g., because interfering echoes cannot be safely distinguished from the echoes of the measured surface. If an echo falls within the far-end blocking range ($LEV < P06$), the device sends a special signal and keeps the level value defined here on the output (see figure). The “Echo in far-end blocking range” flag (see [Chapter 6.1](#)) indicates that the echo is in the far-end blocking zone. Regardless of this, the “VALID” flag is active, but the “HOLD” flag remains inactive.

Far-end blocking can be deactivated with **P06 = 0**. Min. value: 0 / max. value: P04 – P05 – 5 cm (2")

A.) Level or volume measurement

- *If the level drops below the value of P06:*
It keeps a level value corresponding to P06 on the output and calculates the derived values from it.
- *If the level goes above the far-end blocking limit:*
In level or volume measurement mode, the programmed tank dimensions are valid, so far-end blocking does not affect the measured or calculated values.

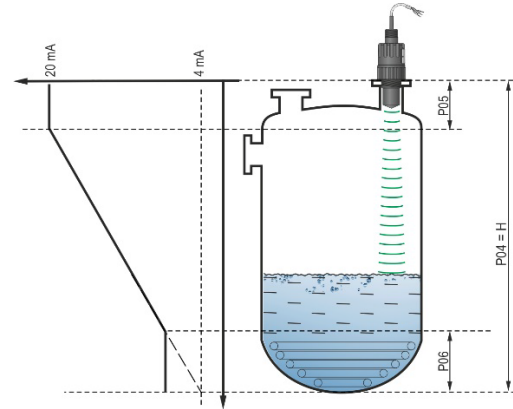

B.) Open-channel flow measurement

Far-end blocking is usually applied to those low-level values, below which exact volume flow cannot be calculated

- *If the level in the flume drops below the blocking value:*
 - The current loop output holds the value corresponding to $Q = 0$.
 - For 0-value transmission via HART “No Flow” or for displaying 0.
- *If the level in the flume rises above the blocking value.*

Flow value is calculated using the parameters specified in the program, so remote blocking does not affect the measured value

EView2 parameter: “Device Settings” → “Measurement optimization” → “Far end (P06)”

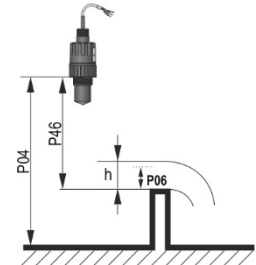

5.3. Current loop output

P08: Manual output current value

FACTORY DEFAULT: 4.0

If the analog current loop output mode (**P12b**) is set to “Manual,” the output current takes the value specified here, and the analog transmission does not work. A value between 3.8...20.5 mA is specified in this parameter. **Caution!** The device automatically switches to “Manual” current output mode when a new value is set in parameter P08. When 0 is entered, the device switches to “Automatic” current transmission mode ($P12b = 0$) and resets the value of parameter P08 to the factory setting.

In HART multi-drop mode (see parameter P19), the current loop output is fixed at 4 mA, as per standard, and the manual output current value (P08) does not apply.

EView2 parameter: “Device Settings” → “Outputs” → “Current output” → “Fix output current (P8)”

P10: The value of the transmitted quantity assigned to 4 mA output current

FACTORY DEFAULT: 0.0

In the case of “Automatic” mode of the analog current output, it is the PV value assigned to 4 mA (usually the lower limit of the measuring range in the case of level measurement). The device scales the (HART – PV, see P01) output value to the analog current output 4...20 mA range using the values specified in parameters P10 and P11.

EView2 parameter: “Device Settings” → “Outputs” → “Current output” → “Assignment of 4 mA – PV”

P11: The value of the transmitted quantity assigned to 20 mA output current

FACTORY DEFAULT: X_{max}
(see P03 table)

In the case of “Automatic” (current transmission) mode of the analog current output, it is the PV assigned to 20 mA (usually the upper limit of the measurement range in the case of level measurement). The device scales the (HART – PV, see P01) output value to the analog current output 4...20 mA range using the values specified in parameters P10 and P11. The values can be assigned in an inverted fashion. (For example, 4 mA to 1 m [3.3 ft] level and 20 mA to 10 m [33 ft] level, or vice versa 20 mA to 1 m [3.3 ft] level and 4 mA to 10 m [33 ft] level. Specify in the order.)

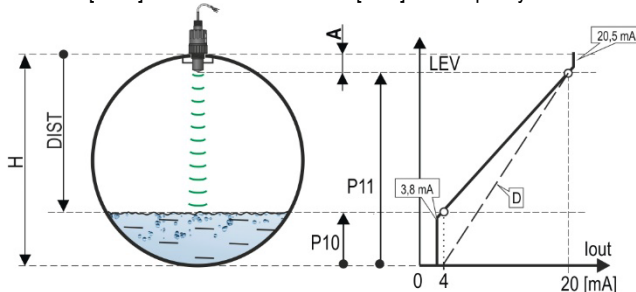

A: Shortest measurable distance

D: **P10, P11** diagram valid for factory default settings

EView2 parameter: “Device Settings” → “Outputs”
→ “Current output” → “Assignment of 20 mA – PV”.

Error current mode: The device indicates the error state on the current output according to the setting below. The error indication set as below persists until the error is cleared.

a	Error current mode
0	HOLD (holding last valid value)
1	3.8 mA
2	22 mA

EView2 parameter: "Device Settings" → "Outputs" → "Current output" → "Error indication by the current output"

Analog current loop mode

b	Analog current loop's mode	Description
0	Automatic (current transmission)	The value of the output current is calculated from the measured value using the parameters P10 and P11. The output of the transmitter is active.
1	Manual	The value of the output current is not calculated from the measured value. Instead, a fixed output current (P08) is sent to the output. In this mode, the setting of the fault current mode is irrelevant. Multi-drop HART communication mode 4 mA (P19) override!

EView2 parameter: "Device Settings" → "Outputs" → "Current generator mode"

Startup mode: when switching on or restarting after a power failure the current is transmitted until the device starts measuring. It is recommended to set it to the fault current of the system. For periodic applications, e.g., battery operation, selecting the "Fast" recovery mode is recommended to shorten the measurement cycle time.

c	Startup mode
0	Normal (3.5 mA)
1	Fast (22 mA)

EView2 parameter: "Device Settings" → "Outputs" → "Startup mode"

5.4. Relay output (optional)

P13: - c b a Relay mode

FACTORY DEFAULT: 0001

a	Operating Mode	Description
0	By PV (P14-P15-P16)	The operating mode of the RELAY optionally built into the device can be set with this parameter. If it is set to "by PV," the RELAY operates based on the triggering (P14) and releasing (P15) values set. The "No ECHO" setting enables a switched (relay contact) error signal to the process controller. Caution! When the device is de-energized, the relay releases, so C1 is ON.
1	"No ECHO" (echo loss): C1 = "On" (release)	
2	"No ECHO" (echo loss): C2 = "On" (energize)	
3	FLOW impulse (P17)	
9	OFF	

View2 parameter: "Device Settings" → "Outputs" → "Relay output" → "Relay mode"

Operating mode: only relevant for operation by PV (P13a = 0)

b	Function		Programmable parameters	Description
0	Hysteresis		P14, P15 At least 20 mm (0.787") hysteresis required between P14 and P15 . P14 > P15 – normal operation P14 < P15 – inverted operation	The basic switching method of the RELAY set to "PV" mode can be adjusted.
1	Window comparator		P14, P15 At least 20 mm (0.787") difference is required between P14 and P15 . P14 > P15 – normal operation P14 < P15 – inverted operation	

View2 parameter: "Device Settings" → "Outputs" → "Relay Function"

FLOW impulse constant's (P17) unit (if P13:a = 3):

c	Metric (EU)	Imperial (US)
0	m ³	ft ³
1	liter	US gallon
2	liter	GB gallon

EView2 parameter: "Device Settings" → "Outputs" → "Relay output" → "Relay parameters" → "Pulse constant unit"

P14: Relay parameter – Trigger value **FACTORY DEFAULT: 0**

Value range	Description
Its value can be adjusted according to the PV setting range	It is the PV measurement value at which we want to indicate on the RELAY output that the upper limit has been reached (upper switching value).

EView2 parameter: "Device Settings" → "Outputs" → "Relay output" → "Relay parameters" → "Energized value"

P15: Relay parameter – Release value **FACTORY DEFAULT: 0**

Value range	Description
Its value can be adjusted according to the PV setting range	It is the PV measurement value at which the RELAY output indicates that the lower limit has been reached (lower switching value).

EView2 parameter: "Device Settings" → "Outputs" → "Relay output" → "Relay parameters" → "De-Energized value"

P16: Relay parameter – Delay **FACTORY DEFAULT: 0**

Value range	Description
0...999 s	If the PV measurement value has reached the lower or upper switching value or an error has occurred in the case of an error signal, the actual RELAY operation is activated after this time, or after this time, a change is visible on the output.

EView2 parameter: "Device Settings" → "Outputs" → "Relay delay time"

P17: Relay parameter – Flow parameter value **FACTORY DEFAULT: 1**

In the case of FLOW, the relay gives a pulse per volume unit specified here. The volume unit can be set in parameter P13:c. The pulse width is 100 ms. The guaranteed maximum pulse density: < 3 seconds.

EView2 parameter: "Device Settings" → "Outputs" → "Relay output" → "Relay parameters" → "Pulse constant"

5.5. Digital communication

P19: HART short address

FACTORY DEFAULT: 0

Unique device address by which the device is identified and managed via HART.

a	Description
0	Analog current loop output is active (4...20 mA current is transmitted)
1...15	Analog current loop output is inactive (no current transmission, fixed 4 mA is present), multi-drop

EView2 parameter: "Device Settings" → "Device Identification" → "Device Short Address"

5.6. Measurement optimization

P20: Damping Time

FACTORY DEFAULT: 10

Damping time reduces unwanted fluctuations in displaying the measured data (e.g., ripples). If the level changes in leaps and bounds, the transmitted value reaches 63.2% of the jump at this time. Unit: second (s). Value range: 0...999 s.

	For testing	Recommended
Barely or not volatile/waving media	0 s	2 s
Strongly volatile/waving media	> 6 s	> 10 s

EView2 parameter: "Device Settings" → "Measurement optimization" → "Damping time"

Damping example 1.
Damping time = 3 s
Level change = 2 m (6.6 ft)

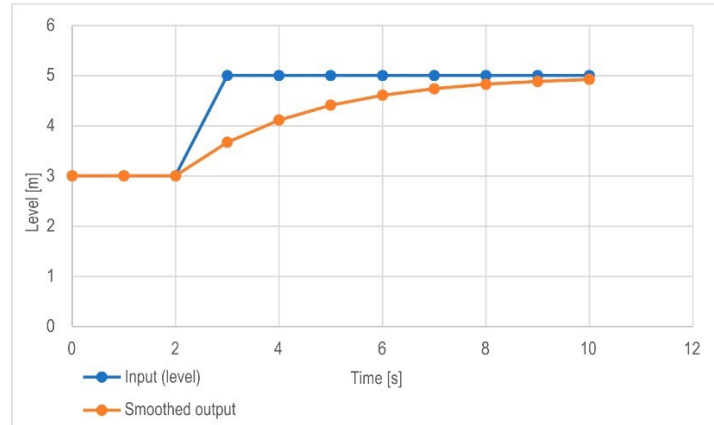

Damping example 2.
Damping time = 10 s
Level change = 2...3 cm
(0.394"...0.787") waving.
If a higher degree of undulation is expected in the measured liquid column, it is recommended to set a higher damping time value. This way, the fluctuation of the value of the transmitted level can be reduced.

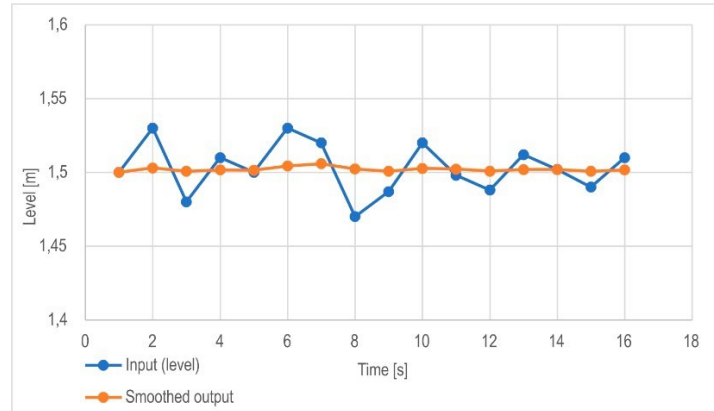

P25: Echo selection**FACTORY DEFAULT: 0**

The parameter sets the echo selection strategy. Automatic operating mode is suitable for most applications. In the case of special application requirements, a specific echo selection can also be set as required.

Echo selection within measuring window	
0	Automatic
1	First
2	Second
3	Largest
4	Last

EView2 parameter: “Device Settings” → “Measurement optimization” → “Echo selection” → “Selection of Echo...”

P26/P27: Level tracking speed**FACTORY DEFAULT: 500 m/h**

The level tracking speed is the fastest level change speed that the device can continuously track. The device will only follow a level change slower than the set value. If the level of the signal changes faster than this, the device indicates a NO ECHO error (according to the error indication settings).

Setting the level tracking speed is important when technological processes, especially during filling or discharging, produce interfering factors (e.g., ripples, foaming) that affect measurement stability. The set level tracking speed must be higher than the maximum filling/discharging speed prescribed by the technology. By entering it correctly, measurements during filling and discharging become more reliable. **Caution! In tanks with a conical or pyramidal bottom, the level change rate at the bottom of the tank increases significantly due to the shape of the tank.**

In this parameter pair, the filling and discharging speed can be set separately:

- P26 – Level elevation rate (filling speed)
- P27 – Level descent rate (emptying speed)
- The parameter’s unit of measure:
- Metric: [m/h]
- US: [ft/h]

EView2 parameter: “Device Settings” → “Measurement optimization” → “Level”

→ “Level elevation rate (filling speed)”

→ “Level descent rate (emptying speed)”

Echo loss management

a	Echo loss ("no-Echo") handling
0	Holding until the period in the P28b decade.
1	Hold (no time limit)
2	Filling simulation (at detected speed)
3	Filling simulation (at P26/P27 maximum speed)
4	Container empty (DIST = maximum / LEV = 0)
5	Container full (DIST minimum / LEV = maximum)

EVView2 parameter: "Device Settings" → "Measurement optimization" → "Measurement loss management" → "Echo loss handling"

Error indication delay

This parameter defines the time elapsed between the occurrence of the error and the issued error signal (error current). During the delay, the output is holding the last valid measured value. The function is available for current output only if the error signal is set to a lower (3.8 mA) or upper (22 mA) error current.

When the error is gone, the device returns to measuring mode after the set delay.

b	Error indication delay	Note
0	No delay	<p>During a short echo loss, the last value is held in transmission for a period set in P28:b. After that, it is transmitted via HART on bit 0 of DSE* according to P12:a on the current loop output.</p>
1	10 s	
2	20 s	
3	30 s	
4	1 min	
5	2 min	
6	5 min	
7	15 min	

*DSE – "Device Specific Error" indicator bits (HART). see Chapter 6. Troubleshooting.

EVView2 parameter: "Device Settings" → "Measurement optimization" → "Measurement loss management" → "Error delay".

P32: Specific density of the measured medium**FACTORY DEFAULT: 1.0**

If the device is set to weight transmission, the specific density of the material (medium) stored in the tank must be entered here for the weight calculation. The value is a relative ratio number (without a unit) compared to the density of water, i.e., 1 g/cm³.

Value range: 0.01...10

EView2 parameter: "Device Settings" → "Measurement optimalization" → "Specific gravity"

P34: (Threshold offset)**FACTORY DEFAULT: 0**

It is used for simple relative modification of the acceptance threshold value set on the Echo diagram, whose value range is -4000...+4000. It can be used to increase (positive value) or decrease (negative value) the device's noise suppression ability compared to the default setting. If the value is set to 0, there is no change compared to the set threshold value. (See chapter 7.4. Threshold mask).

EView2 parameter: "Device Settings" → "Measurement optimalization" → "Threshold offset"

5.7. Volume measurement**P40: d c b a Output value calculation method****FACTORY DEFAULT: 0000**

Selection of typical basic container shapes for volume measurement. The tank dimensions can be set using parameters P41...P45 (see drawings below). In the case of the OCT setting, the container shape must be specified in a table (see chapter 5.9 Output Conversion Table (OCT) programming).

dcba	Container shape	Parameters
1000	Output Conversion Table (OCT)	See Chapter 5.9
00b0	Vertical cylindrical container with a convex bottom	P40(b), P41
0001	Vertical cylindrical container with a conical bottom	P41, P43, P44
0002	Vertical rectangular tank with a pyramidal bottom	P41, P42, P43, P44, P45
00b3	Horizontal cylindrical container	P40(b), P41, P42
0004	Spherical container	P41

EView2 parameter: "Device Settings" → "Tank/Silo parameters" → "Tank/Silo shape"

b	Container bottom shape	
0	Planar	Associating typical container bottom shapes for the specific container type to calculate the volume accurately. The exact form of the setting code can be seen in the drawings under parameters P41...45.
1	Convex 1	
2	Convex 2	
3	Hemispherical	

EView2 parameter: "Device Settings" → "Tank/Silo parameters" → "Bottom shape"

P41–45: - - - Container dimensions

These are the size parameters for the tank shape selected in parameter P40 according to the dimensions shown in the drawings below. **For proper operation, it is important to specify these dimensions accurately.**

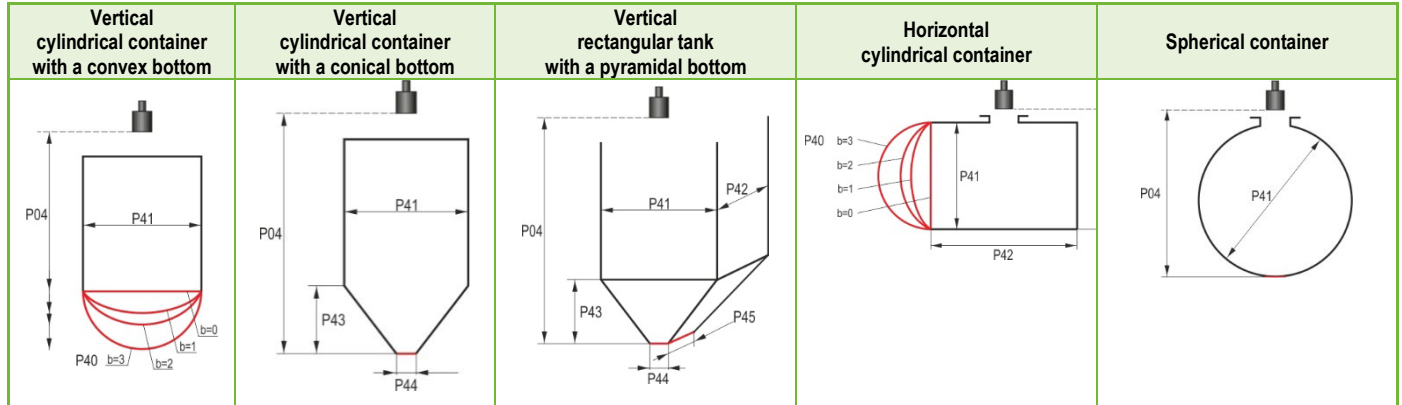

P47: - - - a Total container volume

FACTORY DEFAULT: 0.0

The total container volume is required for calculating the empty volume (see parameter P01). Unit of measure: metric: m³; US/imperial: ft³.

5.8. Open-channel flow measurement

P40: d c b a Volume flow measurement options

FACTORY DEFAULT: 0000

dcba	Flume, formula, data					Parameters	
1000	Output Conversion Table, see Chapter 5.9					P46	
	NIVELCO Parshall flumes	Type	Calculation formula	Qmin [l/s]	Qmax [l/s]	"P" [cm]	
0000		GPA-1P1	$Q [l/s] = 60.87 \cdot h^{1.552}$	0.26	5.38	30	P46
0001		GPA-1P2	$Q [l/s] = 119.7 \cdot h^{1.553}$	0.52	13.3	34	P46
0002		GPA-1P3	$Q [l/s] = 178.4 \cdot h^{1.555}$	0.78	49	39	P46
0003		GPA-1P4	$Q [l/s] = 353.9 \cdot h^{1.558}$	1.52	164	53	P46
0004		GPA-1P5	$Q [l/s] = 521.4 \cdot h^{1.558}$	2.25	360	75	P46
0005		GPA-1P6	$Q [l/s] = 674.6 \cdot h^{1.556}$	2.91	570	120	P46
0006		GPA-1P7	$Q [l/s] = 1014.9 \cdot h^{1.56}$	4.4	890	130	P46
0007		GPA-1P8	$Q [l/s] = 1368 \cdot h^{1.5638}$	5.8	1208	135	P46
0008		GPA-1P9	$Q [l/s] = 2080.5 \cdot h^{1.5689}$	8.7	1850	150	P46
0009	Generic Parshall flume					P46, P42	
0010	Palmer-Bowlus (D/2)					P46, P41	
0011	Palmer-Bowlus (D/3)					P46, P41	
0012	Palmer-Bowlus (rectangular)					P46, P41, P42	
0013	Khafagi Venturi					P46, P42	
0014	Weir					P46, P42	
0015	Rectangular or BAZIN weir					P46, P41, P42	
016	Trapezoidal weir					P46, P41, P42	
0017	Special trapezoidal (4:1) weir					P46, P42	
0018	V-shaped weir					P46, P42	
0019	THOMSON (90°) weir					P46	
0020	Circular weir					P46, P41	
0021	Generic formula: $Q [l/s] = P41 \cdot h^{P42}$, h [m]					P46, P41, P42	
0121	Generic formula: $Q [l/s] = P41 \cdot h^{P42}$, h [P00:cb]					P46, P41, P42	

P40: d c b a Volume flow measurement options (continued)

dcba	Flume, formula, data	Parameters
0100	4" Palmer-Bowlus (D/2)	P46
0101	6" Palmer-Bowlus (D/2)	P46
0102	8" Palmer-Bowlus (D/2)	P46
0103	10" Palmer-Bowlus (D/2)	P46
0104	12" Palmer-Bowlus (D/2)	P46
0105	15" Palmer-Bowlus (D/2)	P46
0106	18" Palmer-Bowlus (D/2)	P46
0107	21" Palmer-Bowlus (D/2)	P46
0108	24" Palmer-Bowlus (D/2)	P46

EView2 parameter: "Device Settings" → "Flow measurement" → "Open channel flow measurement methods"

P40=00
 .
 .
 .
 .
 08
NIVELCO Parshall flume (from GPA1-P1 to GPA-1P9)
 See details in the manual of the Parshall flume.

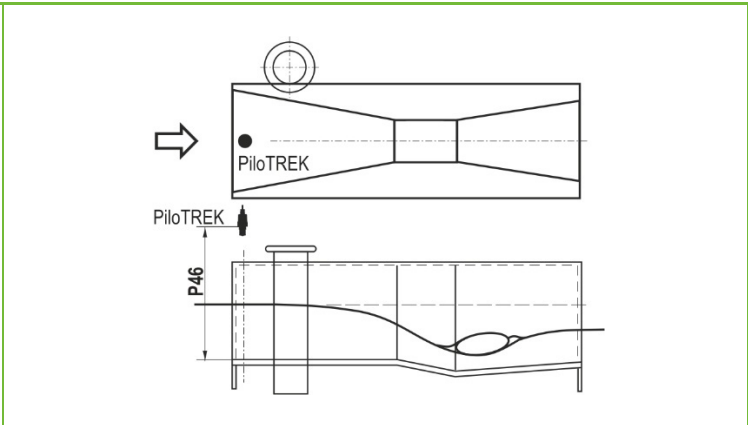

P40=09
Generic Parshall flume
 0.305 < P42 (throat width) < 2.44
 $Q [l/s] = 372 \cdot P42 \cdot (h / 0.305)^{1.569} \cdot P42^{0.026}$
 2.5 < P42
 $Q [l/s] = K \cdot P42 \cdot h^{1.6}$
 $P = 2/3 \cdot A$

P42 [m]	K
3.05	2.450
4.57	2.400
6.10	2.370
7.62	2.350
9.14	2.340
15.24	2.320

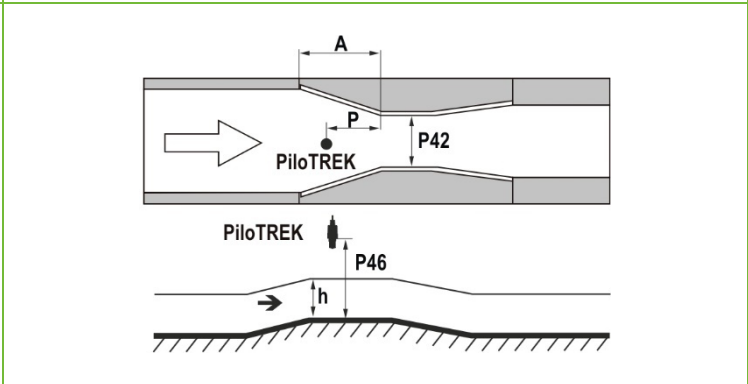

<p>P40=10</p>	<p>Palmer-Bowlus (D/2) flume $Q [m^3/s] = f(h1/P41) \cdot P41^{2.5}$, where $h1[m] = h + (P41/10)$ P41 [m]</p>	
<p>P40=11</p>	<p>Palmer-Bowlus (D/3) flume $Q [m^3/s] = f(h1/P41) \cdot P41^{2.5}$, where $h1[m] = h + (P41/10)$ P41 [m]</p>	
<p>P40=12</p>	<p>Palmer-Bowlus (rectangular) flume $Q [m^3/s] = C \cdot P42 \cdot h^{1.5}$, where $C = f(P41/P42)$ P41 [m], P42 [m]</p>	

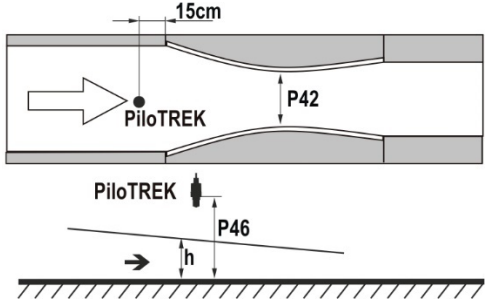
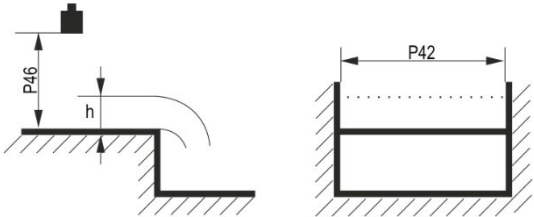
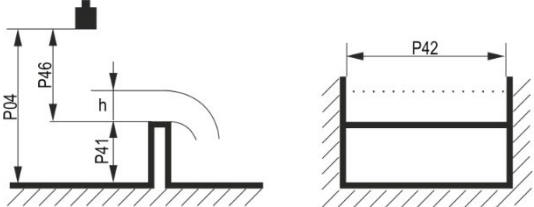
<p>P40=13</p>	<p>Khafagi Venturi flume</p> <p>$Q \text{ [m}^3\text{/s]} = 1.744 \cdot P42 \cdot h^{1.5} + 0.091 \cdot h^{2.5}$</p> <p>P42 [m]</p> <p>h [m]</p>	
<p>P40=14</p>	<p>Step-bottomed weir</p> <p>$0.0005 < Q \text{ [m}^3\text{/s]} < 1$</p> <p>$0.3 < P42 \text{ [m]} < 15$</p> <p>$0.1 < h \text{ [m]} < 10$</p> <p>$Q \text{ [m}^3\text{/s]} = 5.073 \cdot P42 \cdot h^{1.5}$</p> <p>Accuracy: $\pm 10\%$</p>	
<p>P40=15</p>	<p>Square section or BAZIN weir</p> <p>$0.001 < Q \text{ [m}^3\text{/s]} < 5$</p> <p>$0.15 < P41 \text{ [m]} < 0.8$</p> <p>$0.15 < P42 \text{ [m]} < 3$</p> <p>$0.015 < h \text{ [m]} < 0.8$</p> <p>$Q \text{ [m}^3\text{/s]} = 1.77738(1+0.1378h/P41) \cdot P42 \cdot (h+0.0012)^{1.5}$</p> <p>Accuracy: $\pm 1\%$</p>	

<p>P40=16</p>	<p>Trapezoid weir</p> <p>$0.0032 < Q \text{ [m}^3\text{/s]} < 82$</p> <p>$20 < P41[^\circ] < 100$</p> <p>$0.5 < P42 \text{ [m]} < 15$</p> <p>$0.1 < h \text{ [m]} < 2$</p> <p>$Q \text{ [m}^3\text{/s]} = 1.772 \cdot P42 \cdot h^{1.5} + 1.320 \cdot \text{tg}(P41/2) \cdot h^{2.47}$</p> <p>Accuracy: $\pm 5\%$</p>	
<p>P40=17</p>	<p>Special trapezoid (4:1) weir</p> <p>$0.0018 < Q \text{ [m}^3\text{/s]} < 50$</p> <p>$0.3 < P42 \text{ [m]} < 10$</p> <p>$0.1 < h \text{ [m]} < 2$</p> <p>$Q \text{ [m}^3\text{/s]} = 1.866 \cdot P42 \cdot h^{1.5}$</p> <p>Accuracy: $\pm 3\%$</p>	
<p>P40=18</p>	<p>V-notch weir</p> <p>$0.0002 < Q \text{ [m}^3\text{/s]} < 1$</p> <p>$20 < P42[^\circ] < 100$</p> <p>$0.05 < h \text{ [m]} < 1$</p> <p>$Q \text{ [m}^3\text{/s]} = 1.320 \cdot \text{tg}(P42/2) \cdot h^{2.47}$</p> <p>Accuracy: $\pm 3\%$</p>	

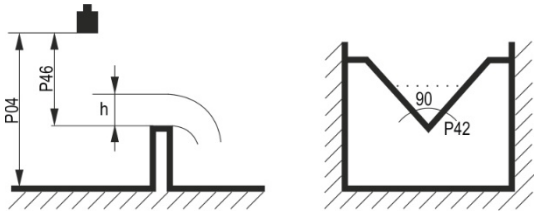
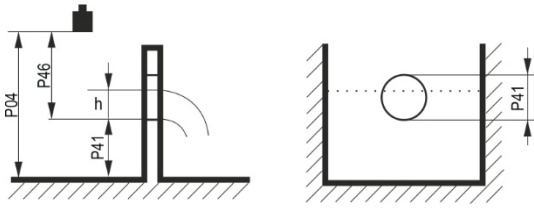
<p>P40=19</p>	<p>THOMSON (90° notch) weir</p> <p>$0.0002 < Q \text{ [m}^3/\text{s]} < 1$</p> <p>$0.05 < h \text{ [m]} < 1$</p> <p>$Q \text{ [m}^3/\text{s]} = 1.320 \cdot h^{2.47}$</p> <p>Accuracy: $\pm 3\%$</p>	
<p>P40=20</p>	<p>Circular weir</p> <p>$0.0003 < Q \text{ [m}^3/\text{s]} < 25$</p> <p>$0.02 < h \text{ [m]} < 2$</p> <p>$Q \text{ [m}^3/\text{s]} = m \cdot b \cdot D^{2.5}$, where $b = f(h/D)$</p> <p>$m = 0.555 + 0.041 \cdot h/P41 + (P41/(0.11 \cdot h))$</p> <p>Accuracy: $\pm 5\%$</p>	

P46: - - - a Distance associated with h=0 when measuring flow

FACTORY DEFAULT: VARIES BY TYPE

P46 is the distance between the sensor's process connection and the liquid's surface, which can be measured at the limit of the start of the flow ($Q = 0$); see figures. Minimum value: $P05 + 5 \text{ cm (2")}$. Maximum value: $P03$.

5.9. Output Conversion Table (OCT) programming

P40: d - - - OCT Operation

FACTORY DEFAULT: 0

An output signal of any characteristic can be assigned to the level values measured by the device. The output signal unit is the unit set in parameter $P02$ of the output data type assigned to the "HART - PV" output in parameter $P01$. The characteristic can be specified with a maximum of 100 points. Between the points, the device calculates the output signal from the measured level by linear interpolation and after the last point by linear extrapolation. The OCT can be used to assign the measured level to an arbitrary output signal. Its typical application is the calculation of level to volume for containers that are not included in the tank shape list (e.g., dented) and specifying individual channel characteristics in the case of open channel flow measurement.

d	Calculation method
0	Container shape formula (see Chapter 5.7)
1	OCT (see Chapter 7.4)

EView2 parameter: "Device Settings" → "OC-Table" → "Linearization"

Conditions for correct programming of data pairs

- The table must start with L(1)= 0 and R(1)= is the output quantity assigned to it.
- Column "L" may not contain identical values.
- Columns "L" and "R" can only have increasing values from top to bottom.
- If the table contains less than 100 points, column "L", in the row following the last valuable data pair, must be 0.

i	L (left column) MEASURED LEVEL	R (right column) OUTPUT VARIABLE
1	0	R(1)
2	L(2)	R(2)
	L(i)	R(i)
nn	L(nn)	R(nn)
nn+1	0	
100		

EView2 parameter: "Device Settings" → "OC-Table" → "OCT list"

5.10. Service diagnostic parameters (read only)

P60:	----	Number of operating hours since issuing [h]
P61:	----	The number of operating hours since the last power-on [h]
P62:	----	The number of operating hours of the relay (closed time of contact C2) [h]
P63:	----	The number of switching cycles of the relay
P64:	----	The current temperature of the device's electronics [°C / °F]
P65:	----	The highest temperature of the device ever measured [°C / °F]
P66:	----	The lowest temperature of the device ever measured [°C / °F]
P70:	----	Number of detected peaks (current)
P71:	----	Magnitude of selected echo (raw value)
P72:	----	The amplitude of the selected echo [dB]
P73:		The distance of the selected echo [m]
P74:		Echo lost/shot ratio

5.11. Flow measurement control parameters (read only)

P76:	----	Measuring height of the flow measurement ('h' value)
------	------	--

Measuring height required for flow measurement. This value is the "h" value in the flow calculation formula.

P77:	----	TOT1 totalizer (can be cleared)
P78:	----	TOT2 totalizer

5.12. Output control parameters (read only)

P79:	----	Current generator re-measured output current [µA]
P80:	----	Current generator calculated output current [mA]
P81:	----	Relay output status

5.13. Hardware / Software versions (read only)

P94/95:	----	Software code 2 / 3 (SLAVE MCUs)
P96:	----	Software code 3 (MAIN MCU)
P97/98:	----	Hardware identification code

6. TROUBLESHOOTING

6.1. Status and error indication in HART communication

The response code, according to the HART® standard, is two 16-bit words after the response code bytes, in the order Errors and Warnings, then Status. If it is impossible to query the status and error code via HART®, then the indication of the LEDs on the device must be monitored. Errors indicated by the status LEDs are described in [Chapter 4.6](#).

Bit №	“Device Specific Error/Warning” flags	Meaning, possible reason, solution
0	No echo (<i>Warning</i>)	The device cannot detect the surface to be measured, so there is no echo or there are too many echoes due to interference. Ensure proper installation! If the problem persists, contact the dealership.
1	EEPROM is not detected (<i>Error</i>)	The parameter memory of the device is compromised. Contact dealership.
2	EEPROM checksum error detected (<i>Error</i>)	Some data stored in the device's parameter memory has been corrupted. Factory default settings are restored by the device. If the device's parameter memory fails frequently, contact the dealership.
3	OCT input side integrity error (<i>Error</i>)	The data in the left (L) column of the Output Conversion Table (OCT) is not incremental. Correct it.
4	OCT output side integrity error (<i>Error</i>)	The data in the right (R) column of the Output Conversion Table (OCT) is not incremental. Correct it.
5	OCT item count is < 2 (<i>Error</i>)	Too few points are entered into the Output Conversion Table (OCT). At least two ($i \geq 2$) points (elements) must be entered.
6	Input level over the OCT input side (overload) (<i>Warning</i>)	The measured level, as the input value of the OCT, points out of the range entered in the left (L) column of the OCT. Enhance the range.
7	EEPROM reinitiated (EEPROM layout damaged or missing) (<i>Error</i>)	The data structure stored in the device's parameter memory is corrupted. The device restored the factory default settings. If the device's parameter memory fails frequently, contact the dealership!
8	—	—
9	Echo in near blocking range	The measured surface is too close, within the device's minimum measuring range (X_{min}). Set the close-end blocking (P05) to a smaller value, or change the technology to ensure that the surface to be measured does not come so close to the sensor of the device.
10	Echo in far blocking range	The measured surface is too far, outside the device's maximum measuring range (X_{max}). Set the far-end blocking (P05) to a larger value, or change the technology to ensure that the surface to be measured does not get so far from the sensor of the device.
11	—	—
12	One or more slave controller(s) failure!	One of the device's auxiliary controllers has failed. The probability of a firmware error is high. Performing a complete firmware update with NiFlash (including synchronization) may solve the problem. If unsuccessful, contact the dealership.
13	Relay failure	If the device has an optional relay, it is faulty. Contact the dealership.

14	Parameter table integrity error	The value of one or more parameters is not consistent with the associated parameters. Correct the parameter value.
15	Sensor failure	The radar sensor is faulty. There can be several reasons for this, e.g., the data connection with the radar sensor unit is inadequate or insufficient energy available for the measurement. The terminal voltage of the device must be above the prescribed minimum in all circumstances! Check the voltage conditions of the loop by measurement and change it as necessary so that the electrical conditions for the terminals of the device are met. Contact the dealership if the power supply voltage level is correct and the error persists.

Bit №	"Device Specific Status" flags (DSS)	Explanation
0-2	PV value type (DIST, LEV, VOL, MASS, FLOW, LEV%, VOL%, ...)	The type of the primary transmitted value (PV) by P01a.
3	Manual programming is active	The device is in manual programming mode. (Only on devices (WG□) featuring a display.)
4	Remote programming is active	The device is in remote programming mode.
5	Simulation is active	The device is in simulation mode. Caution! The output value is independent of the measured value.
6	User password is set	Password protection is on.
7	Relay energized	Relay is energized.
8	User lock is active	User lock is active. The parameters are protected by a password set by the user.
9	Factory lock is active	Factory lock is active. The factory default settings and calibration data are locked.
10	SAP display is connected	An SAP display is connected to the device. (Only on devices (WG□) featuring a display.)
11	Diagnostic mode is active	The device is in diagnostic mode.
12	HOLD	The transmitted value is held.
13	Calibration mode is active	The device is in calibration mode.
14	Valid	The transmitted value is refreshed and valid.
15	HS communication mode is active	The device is in high-speed communication mode.

7. EView2 INSTRUCTIONS

General information about the EView2 program can be found in [Chapter 5.1](#) and in the EView2 user manual. This chapter only shows the special features related to the PilotREK and two programming examples.

7.1. Device Status Window

To invoke the “Device Status Window” in EView2, right-click on the device line in the “Device List” in the main window and select the “Show Device Status Window” menu item in the popup window. This window shows the status and error messages of the PilotREK. (See [Chapter 6.1](#)) The “Device Status Window” can also be summoned in the “Polling” window by activating the corresponding check box.

7.2. Echo Diagram oscilloscope function

Click the “Echo Diagram” button in EView2 to display the device’s Echo Diagram. A window called “Echo map” will appear. This diagram shows the reflection curve measured by the device. In addition, this window can be used to adjust the “Threshold” level.

To update the chart or read the data, press the “Refresh” button on the bottom line of the window (or press the F4 key).

After a successful reading, an echo graph similar to the attached “Echo Diagram” appears. The displayed information content can be selected in the legend. The “Echo list” displays the location and data of the echo peaks evaluated by the device, of which the selected level signal is marked with the inscription “Selected peak.”

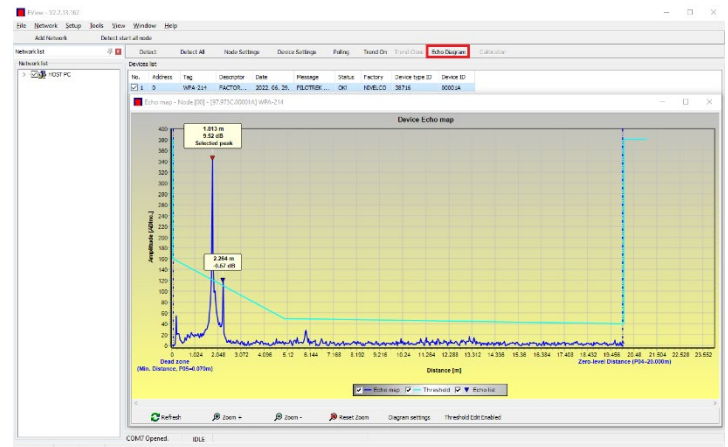

7.3. Threshold settings

The function is intended for advanced users. Incorrect setting may render the device unable to measure!

The purpose of the threshold value and the threshold line is to mask unwanted echoes from the measurement. Echo peaks below the threshold level are not taken into account in the evaluation. Setting the threshold may be necessary if the device selects an inappropriate echo peak as the level, for example because there is an interfering object in the path of the ultrasound during the measurement. Before changing the threshold curve, it is recommended to minimize interfering echoes by selecting the correct installation location of the device.

The threshold can be edited in the Echo diagram window of the EView2 program. In addition, the height of the entire threshold can be adjusted in a simplified way with the P34 “Threshold offset” parameter among the measurement optimization parameters. The main threshold line is used to trace the general shape of the echo curve. Threshold highlights, also known as threshold masks, are available to mask interfering echo peaks protruding from the curve.

The threshold editing mode can be activated either by selecting “Threshold Edit Enable” in the bottom menu bar or by selecting “Threshold settings” → “Threshold Edit Enable” in the context menu that appears when clicking the right mouse button. In this case, the threshold editing function bar appears in the upper half of the window, and the editable points are marked red on the threshold curve. If no editable point is selected, the “Threshold offset” can be set in the function bar, so the height of the basic threshold curve consisting of three points is the same. If an editable point is selected by clicking the left mouse button, its position can also be altered separately. Threshold points can also be moved with the mouse by clicking and holding the left mouse button over the selected point.

The changes only take effect in the device after pressing the “Apply Threshold settings” button, which can also be found in the threshold editing function bar or the context menu. To display the evaluation corresponding to the new threshold, refresh the chart with the “Refresh” button in the bottom menu bar (or the F4 function key).

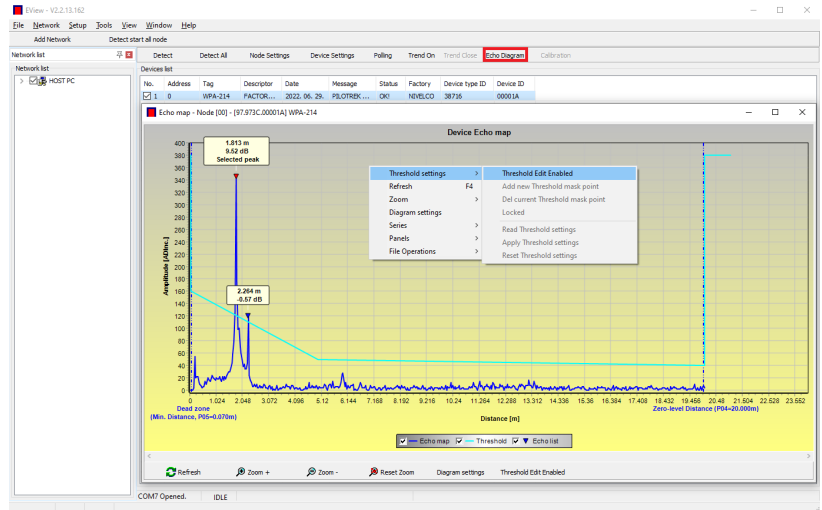

7.4. Threshold mask

The “Threshold Mask” function masks an echo peak that interferes with the measurement. To do this, after pressing the “Add new threshold mask” button in the threshold editing function bar, click the left mouse button in the diagram over the position where you want to place the threshold highlight, or if using the context menu, click with the right mouse button on the desired position, then select the “Add new threshold mask” function. The position and width of the threshold mask can also be adjusted afterwards in the threshold editing function bar by selecting the center point of the highlight as described above. In the case of graphic editing, its position and height can be adjusted by dragging the center point, and its width can be adjusted by dragging the corner point. A total of 4 threshold highlights can be defined. If there are more interfering echoes than 4, it is better to choose another mounting position.

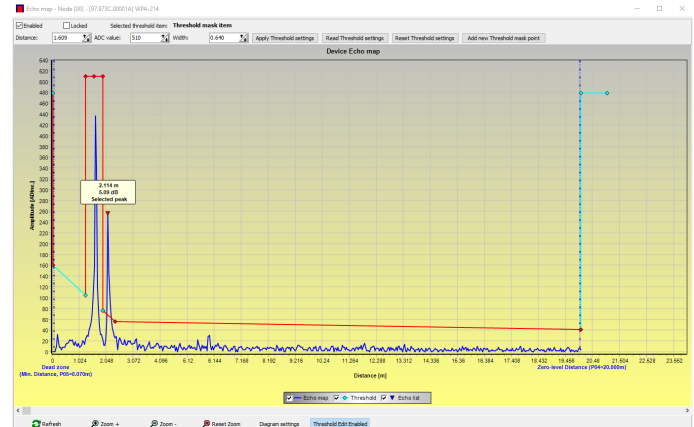
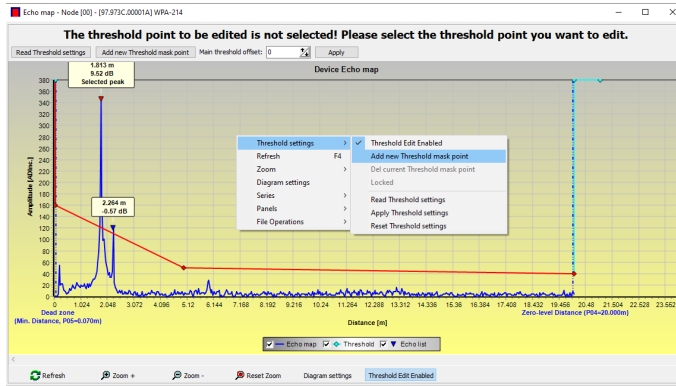

Caution! The “Cursor On” function does not provide an exact value. It only calculates the value of a given point based on the graphical representation. The threshold highlight can be deleted by selecting its center point, or turning the “Enabled” switch off in the threshold editing function bar, or selecting the “Del current threshold mask” function in the context menu. Until the changes are applied to the device with the “Apply Threshold settings” function, it uses the previous (current) threshold settings, which can be read with the “Read Threshold settings” function. The factory default settings can be restored with the “Reset Threshold Settings” function.

7.5. The output conversion table (OCT) – (EView2 OC-Table)

The output conversion table (OCT) is active if table correction is selected in parameter P40. See [Chapters 5.7](#), [5.8](#), and [5.9](#). The OCT is filled in using the EView2 program. The conversion table is usually used for volume measurement but can also be used for weight or flow measurement. This table assigns different output values to the measured levels. The value on the left is always the measured level (relative to the zero-level distance (P04) setting), and the value on the right is the output value for the particular level. The unit associated with the output value is determined by the setting of the “Output source” (P01, HART - PV) and “Output units” (P02) parameters. The output value is determined by linear interpolation between two value pairs, so the accuracy of the conversion depends on the density of the associated value pairs. After the last pair of points, the output value is calculated by linear extrapolation. The maximum number of pairs is 100.

More information

- Each new level value entered must be greater than the previous one.
- The length and volume units can be changed later on without changing the data in the table (Length unit, Volume unit). Attention, the units in the table are always interpreted by the device according to the currently set units of measure. Therefore, the OCT must always be filled in with values corresponding to the set units.
- **Caution!** When using the conversion table, the setting of the current output (P10/P11) is also interpreted according to the value range (and measurement unit) defined on the left side of the table. Accordingly, the appropriate setting of the P10/P11 parameters is recommended after uploading the table.
- If the conversion table is filled in incorrectly, the output (transmitted) value will not be correct either!

A user-defined conversion table (e.g., “level - volume”) can be created using EView2 as follows:

To fill in or set the output conversion (OC) table of the device, go to the “Device Settings” → “OC-Table” tab in EView2. Upload or modify the table according to “EView2 Instructions for Use – Chapter 6.4.” If the appropriate changes have been made in the table and it has been filled in correctly, press the “Send” button on this page (“OC-Table” tab) on the right side under the “Get” button to download the table to the device.

In the following example, five-point programming is presented, example: “Level - Volume” conversion

Step	Action	Entered data / chosen value
1	In EView2, open the “Device Settings” window of the given device.	
2	Go to the point called “Application” and select the unit system (“Calculation system”).	Metric (EU)
3	Select a length unit.	m
4	Go to “Measurement configuration” and select “Measurement mode (PV source): volume transmission” from the list.	Volume
5	Select a volume unit in the “Volume Units” section.	m ³
6	Go to “Measuring distances” and enter the tank height in the field named “Zero-level dist.” (Click on the field and enter the value).	6.00 m (20.00 ft)
9	Press the “Send” button in the lower right corner of the window to download the new values to the device.	Wait until the download process is complete.
10	Go to the point called “OC-Table.” Fill in the table called “OCT list” with the appropriate values. A maximum of 100 points can be entered. Each level and volume point must be entered. Each subsequent point must be larger than the previous one. <i>New lines can be created by pressing the “Ctrl + Insert” key combination or selecting “Add new item” in the popup menu of the right mouse button.</i> <i>A line can be deleted by pressing the “Ctrl + D” keys together.</i>	See the following table (Example for completing OCT)
11	To download the table to the device, press the “Send” button located on this page (“OC-Table” tab) on the right side under the “Get” button.	

Example of filling out the OCT

Point	Level (Source column)	Volume (Output column)
1	0.0 m (0.0 ft)	0.0 m ³ (0.0 ft ³)
2	0.20 m (0.66 ft)	0.5 m ³ (17.6 ft ³)
3	0.75 m (2.46 ft)	1.0 m ³ (35.3 ft ³)
4	1.00 m (3.30 ft)	1.5 m ³ (53 ft ³)
5	5.60 m (18.37 ft)	16.8 m ³ (593.3 ft ³)

Additional procedure for displaying 4...20 mA current output (using EView2)

Step	Action	Entered data / chosen value
1	Go to "Outputs" and set "Current generator mode" to "Auto" (default setting)	Auto
2	In the "Error indication ..." field, set the error status to the appropriate mode (default setting).	Hold-
3	Select "Assignment of 4 mA - PV (P10)" and enter the volume value corresponding to the output current value of 4 mA.	0.5 m ³ (17.6 ft ³)
4	Select "Assignment of 20 mA- PV (P11)" and enter the volume value corresponding to the output current value of 20 mA.	16.8 m ³ (593.3 ft ³)
5	Press the "Send" button in the lower right line of the window to download the new values to the device.	
6	Press the "X" close button to exit the device settings window.	

7.6. Programming example 1 – configuring level measurement (using EView2)

Configuring level measurement in a 9 m (29.5 ft) tank (example). Level measurement is the factory default mode, it is sufficient to enter only the actual tank height (P04 = 9.0 m [29.5 ft]). The maximum measuring length of the WP-200 radar configured by the manufacturer is 10.0 m (33 ft), so it covers the required 9 m (29.5 ft).

Step	Action	Entered data / chosen value
1	Open the "Device Settings" window corresponding to the given device in EView2.	The program reads and displays the device settings.
2	Select "Measurement configuration."	
3	Click on "Zero-level dist." (Zero-level distance) field.	Data in the field: 10.000 [m] (33.000 [ft])
4	Enter the new value.	9.000 [m] (29.500 [ft])
5	Press the "Send" button in the lower right corner of the window to download the new value to the device.	The device will work according to the new settings after the download is complete.
6	Press the "X" close button to exit the device settings window.	

7.7. Programming example 2 – configuring the current loop output (using EView2)

Custom scale setting: Example: 4 mA indicates the 1 m level [3.3 ft], 20 mA indicates the full tank, for example 8 m (26.2 ft) maximum level, upper error current.

Set current range 4...20 mA with 22 mA error indication.

Choose a suitable minimum and maximum value for the scale of the measurement

Step	Action	Entered data / chosen value
1	In EView2, open the "Device Settings" window corresponding to the given device.	The program reads the device settings and displays them.
4	Select "Outputs"	
5	Select the "Error indication ..." drop-down list.	The field will read "Hold"
6	Select the new setting value (22 mA) in the drop-down list.	The field will read "22 mA"
7	Select the "Assignment of 4 mA - PV" data field.	The field will read "0.000 [m]" (0.000 [ft])
8	Enter the new value. This sets the level corresponding to a minimum output of 4 mA (1 m).	The field will read "1.000 [m]" (3.300 [ft])
9	Select the "Assignment of 20 mA - PV" data field.	The field will show the maximum measuring distance by default.
10	Switch to 8.000 m (26.20 ft). This sets the level corresponding to a maximum output of 20 mA (8 m [26.2 ft]).	The field will read "8.000 [m]" (26.20 [ft])
11	Press the "Send" button in the lower right line of the window to download the new values to the device.	After the download is complete, the device will use the new settings.
12	Press the "X" close button to exit the device settings window.	

8. PARAMETER LIST

Pr.	Page	Name	Value				Pr.	Page	Name	Value			
			d	c	b	a				d	c	b	a
P00	16	Unit system, default unit					P20	26	Damping Time				
P01	17	Output source					P21		—				
P02	18	Output units					P22		—				
P03	19	Maximum detection distance					P23		—				
P04	20	Zero-level distance (container height – H)					P24		—				
P05	20	Close-end blocking (dead-zone)					P25	28	Echo selection				
P06	20	Far-end blocking					P26	28	Level tracking speed				
P07		—					P28	28	Measurement loss management				
P08	22	Manual output current value					P29		—				
P09		—					P30		—				
P10	22	Output value assigned to 4 mA					P31		—				
P11	22	Output value assigned to 20 mA					P32	29	Density of measured medium				
P12	23	Analog current loop output's mode					P34	30	Threshold offset				
P13	24	Relay output					P40	31	Container shape				
P14	25	Relay parameter – Trigger value					P41	32	Container dimensions / Volume flow options				
P15	25	Relay parameter – Release value					P42	34	Container dimensions / Flume – weir dimensions				
P16	25	Relay parameter – Delay					P43	35	Container dimensions / Flume – weir dimensions				
P17	25	Relay parameter – Flow parameter value					P44	36	Container dimensions / Flume – weir dimensions				
P18		—					P45	37	Container dimensions / Flume – weir dimensions				
P19	26	HART address					P46	38	The distance to the surface without flow				
							P47	39	Total container volume				

Pr.	Page	Name	Pr.	Page	Name
P60	40	Number of operating hours since issuing [h]	P80	40	Current generator calculated output current [mA]
P61	40	The number of operating hours since the last power-on [h]	P81	40	Status of relay outputs
P62	40	The number of operating hours of the signal detector (closed time of contact C2) [h]	P82	—	—
P63	40	The number of switching cycles of the relay	P83	—	—
P64	40	The current temperature of the electronics [°C / °F]	P84	—	—
P65	40	The highest temperature of the device ever measured [°C / °F]	P85	—	—
P66	40	The lowest temperature of the device ever measured [°C / °F]	P86	—	—
P67	—	—	P87	—	—
P68	—	—	P88	—	—
P69	—	—	P89	—	—
P70	40	Number of detected peaks (current)	P90	—	—
P71	40	Magnitude of selected echo [raw value]	P91	—	—
P72	40	Amplitude of selected echo [dB]	P92	—	—
P73	40	Distance of selected echo [m]	P93	—	—
P74	40	Echo lost/shot rate	P94	40	Software code (RADAR)
P75	—	—	P95	40	Software code (COPROC)
P76	40	Measuring height of the flow measurement (read only) (LEV)	P96	40	Software code (MAIN MCU)
P77	40	TOT1 totalizer (clearable)	P97	40	Special config mode (read only)
P78	40	TOT2 totalizer	P98	40	Hardware code (read only)
P79	40	Current generator re-measured output current [μA]	P99	—	—

wpa200en22p01

May 2022

NIVELCO reserves the right to change anything in this manual without notice!